

Installation, Operation and Maintenance Manual

Please read and save these instructions for future reference. Read carefully before attempting to assemble, install, operate or maintain the product described. Protect yourself and others by observing all safety information. Failure to comply with instructions could result in personal injury and/or property damage!

Grease Grabber™ Triple Play

The Accurex Grease Grabber™ Triple Play is a pre-engineered mechanical filtration pollution control unit with integral exhaust fan (available without exhaust fan as an option). The unit is designed to remove grease and smoke particles as well as odor molecules from the kitchen exhaust airstream. This installation manual covers procedures for receiving, installing, and maintaining the filtered section of the unit.

For additional instructions and maintenance information on the integral exhaust fan, when applicable, refer to the fan nameplate to determine model type and visit www.accurex-systems.com to download the corresponding manual.

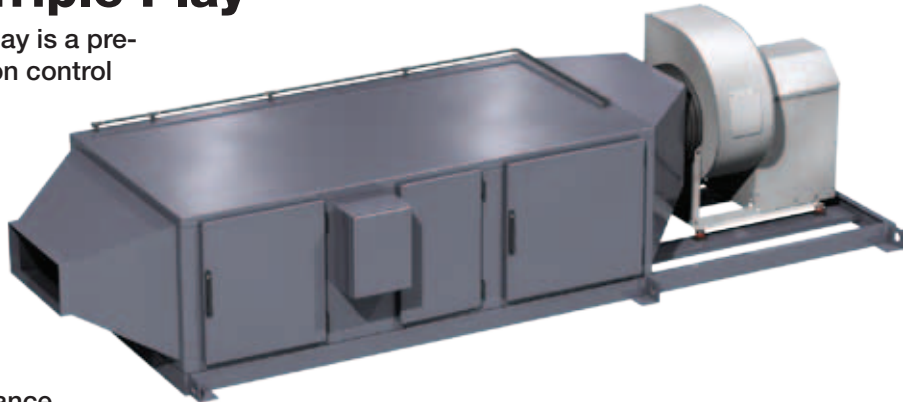

General Safety Information

Only qualified personnel should install this system. Personnel should have a clear understanding of these instructions and should be aware of general safety precautions. Improper installation can result in electric shock, possible injury due to coming in contact with moving parts, as well as other potential hazards. Other considerations may be required if high winds or seismic activity are present. If more information is needed, contact a licensed professional engineer before moving forward.

- Follow all local electrical and safety codes, as well as the National Electrical Code (NEC), the National Fire Protection Agency (NFPA), where applicable. Follow the Canadian Electric Code (CEC) in Canada.
- The rotation of the fan wheel is critical. It must be free to rotate without striking or rubbing any stationary objects.
- Fan motor must be securely and adequately grounded.
- Do not spin fan wheel faster than maximum cataloged fan rpm. Adjustments to fan speed significantly effects motor load. If the fan RPM is changed, the motor current should be checked to make sure it is not exceeding the motor nameplate amps.
- Do not allow the power cable to kink or come in contact with oil, grease, hot surfaces or chemicals. Replace cord immediately if damaged.
- Verify that the power source is compatible with the equipment.
- Never open access doors to a duct while the fan is running.

DANGER

Always disconnect power before working on or near a fan. Lock and tag the disconnect switch or breaker to prevent accidental power up.

CAUTION

When servicing the fan, motor may be hot enough to cause pain or injury. Allow motor to cool before servicing.

CAUTION

Precaution should be taken in explosive atmospheres.

Receiving

Upon receiving the product check to make sure all items are accounted for by referencing the packing list ensuring all items were received. Inspect each crate for shipping damage before accepting delivery. Notify the carrier if any damage is noticed. The carrier will make notification on the delivery receipt acknowledging any damage to the product. All damage should be noted on all the copies of the bill of lading which is countersigned by the delivering carrier. A Carrier Inspection Report should be filled out by the carrier upon arrival and filed with the Traffic Department. If damaged upon arrival, file claim with carrier. Any physical damage to the unit after acceptance is not the responsibility of Accurex, LLC.

Unpacking

Verify that all required parts and the correct quantity of each item have been received. If any items are missing, report shortages to your local representative to arrange for obtaining missing parts. Sometimes it is not possible that all items for the unit be shipped together due to availability of transportation and truck space. Confirmation of shipment(s) must be limited to only items on the bill of lading. Filters are shipped on a separate skid in their original packaging. Do not remove factory packaging or install filters until just prior to commissioning. Remove all other shipping/packing materials including fan tie down straps.

Handling

Units are to be rigged and moved by the lifting brackets provided or by the skid when a forklift is used. Location of brackets varies by model and size. Handle in such a manner as to keep from scratching or chipping the coating. Damaged finish may reduce ability of unit to resist corrosion.

Storage

Units are protected against damage during shipment. If the unit cannot be installed and operated immediately, precautions need to be taken to prevent deterioration of the unit during storage. The user assumes responsibility of the unit and accessories while in storage. The manufacturer will not be responsible for damage during storage. These suggestions are provided solely as a convenience to the user.

INDOOR

The ideal environment for the storage of units and accessories is indoors, above grade, in a low humidity atmosphere which is sealed to prevent the entry of blowing dust, rain, or snow. Temperatures should be evenly maintained between 30°F (-1°C) and 110°F (43°C) (wide temperature swings may cause condensation and “sweating” of metal parts). All accessories must be stored indoors in a clean, dry atmosphere.

Remove any accumulations of dirt, water, ice, or snow and wipe dry before moving to indoor storage. To avoid “sweating” of metal parts allow cold parts to

reach room temperature. To dry parts and packages, use a portable electric heater to get rid of any moisture buildup. Leave coverings loose to permit air circulation and to allow for periodic inspection.

OUTDOOR

Units designed for outdoor applications may be stored outdoors, if absolutely necessary. Roads or aisles for portable cranes and hauling equipment are needed.

The unit should be placed on a level surface to prevent water from leaking into it. The unit should be elevated on an adequate number of wooden blocks so that it is above water and snow levels and has enough blocking to prevent it from settling into soft ground. Locate parts far enough apart to permit air circulation, sunlight, and space for periodic inspection. To minimize water accumulation, place all unit parts on blocking supports so that rain water will run off.

Do not cover parts with plastic film or tarps as these cause condensation of moisture from the air passing through heating and cooling cycles.

Inspection and Maintenance during Storage

While in storage, inspect fans once per month. Keep a record of inspection and maintenance performed.

If moisture or dirt accumulations are found on parts, the source should be located and eliminated. At each inspection, rotate the fan wheel by hand ten to fifteen revolutions to distribute lubricant on motor. Every three months, the fan motor should be energized. If paint deterioration begins, consideration should be given to touch-up or repainting. Fans with special coatings may require special techniques for touch-up or repair.

Machined parts coated with rust preventive should be restored to good condition promptly if signs of rust occur. Immediately remove the original rust preventive coating with petroleum solvent and clean with lint-free cloths. Polish any remaining rust from surface with crocus cloth or fine emery paper and oil. Do not destroy the continuity of the surfaces. Wipe thoroughly clean with Tectyl® 506 (Ashland Inc.) or the equivalent. For hard to reach internal surfaces or for occasional use, consider using Tectyl® 511M Rust Preventive or WD-40® or the equivalent.

Removing from Storage

As units are removed from storage to be installed in their final location, they should be protected and maintained in a similar fashion, until the equipment goes into operation. Prior to installing the unit and system components, inspect the unit assembly to make sure it is in working order.

1. Check all fasteners, set screws on the fan, wheel, bearings, drive, motor base, and accessories for tightness.
2. Rotate the fan wheel(s), where applicable, by hand and assure no parts are rubbing.



Table of Contents

Installation 4
 Rigging/Placing Equipment..... 4
 Duct Connections 4
 Electrical Connections..... 4
 Fire System 5
 Filter Installation..... 5
Operation 5
 Start-Up 5
 Filter Status Indicator 5
 Filter Replacement..... 6
 Carbon Panel Replacement 6
Maintenance 6
 Regular Scheduled Maintenance 6
 Replacement Filter/Parts Ordering 6
Figures #1 and #2 7
Wiring Diagram 8-9
Maintenance Log..... 10-11
Warranty..... 12



Grease Grabber Triple Play System Function

Grease Grabber Triple Play is a 3-stage mechanical air filtration unit, with an additional carbon filter module, designed for two specific functions:

- Remove smoke/grease particulate from kitchen exhaust.
- Remove odor molecules from kitchen exhaust.

NOTE
Grease Grabber Triple Play must be connected to a listed exhaust hood assembly and must be installed in accordance with local building codes, NFPA 96 and NEC.
NOTE
Grease Grabber Triple Play is not intended for use with solid fuel cooking appliances.
NOTE
The unit must be installed with a minimum 18 inch clearance to combustible materials and must be installed as part of a listed duct assembly.

Filter stages 1, 2 and 3 are mechanical air filters of progressive filtration efficiency that retain the smoke and grease particles.

Each filter stage is monitored by an individual pressure switch that signals when a particular filter stage needs replacing. The pressure switches are located inside the Pressure Switch Enclosure located on the access door side of Triple Play housing, between filter stages 2 and 3. When a filter stage requires replacement, a signal from the pressure switch lights an LED located on the remote mounted Filter Status Indicator. This enclosure must be field mounted in an area convenient for monitoring by the cook staff.

System Components

Cabinet Assembly

The unit body is shipped on a common mounting rail ready for installation. If the unit was ordered with an exhaust fan, the fan will also be mounted as part of the cabinet assembly.

Filters

Filter quantity for each filter stage is based on unit size. A consistent quantity of filters is provided for each stage of filtration (pre-filter, bag filter, and rigid final filter). Quantity of carbon panels will vary based upon unit exhaust rate.

Unit Size	Filter Quantity (each)
10-10	1
10-20	2
10-30	3
20-20	4
20-30	6
20-40	8
30-30	9
30-40	12
40-40	16
40-50	20

Remote Status Indicator (See Page 6)

At time of delivery, a remote status indicator is mounted within the rigid filter section of the unit body. This item must be removed and mounted remotely in the cooking area prior to unit start-up.



Installation

Rigging/Placing Equipment (See Figure #1)

1. The unit is furnished with lifting lugs at the four corners and along the length as necessary.
2. Lift into place using all the lifting lugs.
3. Field weight will vary depending upon final selections such as fan type, accessories, etc. Approximate weights are shown in the table below.

Unit Size	Approximate Weight (lbs)	Approximate Weight (kg)
10-10	1100	500
10-20	1600	727
10-30	2150	977
20-20	2600	1182
20-30	3500	1591
20-40	4200	1909
30-30	4700	2136
30-40	5700	2591
40-40	7300	3318
40-50	8000	3636

4. The unit can be positioned on a base or curb suitable for this purpose.
5. The unit must be anchored to its base/curb.
6. Alternatively, the unit may be suspended from an adequate overhead structure, using suitable undercarriage or hanging rods (by others). If the unit is suspended by hanging rods, minimum 1/2 inch (12.7 mm) diameter threaded rod is to be used. All hanger brackets/lifting lugs must be used to ensure proper support of the unit. The unit must also be hung level to ensure proper operation.
7. A service clearance of 36 inches must be provided on the access door side of the unit.
8. A minimum 18-inch clearance must be maintained between this unit and any combustible material.
9. The remote Filter Status Indicator (See Page 6) should be located in an area convenient for monitoring by the cook staff. For details on wiring this item, refer to the Electrical Connections section on this page.

Duct Connections

Ductwork must conform to the IMC and SMACNA guidelines.

As specified in NFPA 96, Ch. 7.5 (latest edition), exhaust duct systems must be constructed in the following manner; unless otherwise specified by the local authority having jurisdiction (AHJ):

Materials

Ducts shall be constructed of and supported by carbon steel not less than 1.37 mm (0.054 in.) (No. 16 MSG) in thickness or stainless steel not less than 1.09 mm (0.043 in.) (No. 18 MSG) in thickness.

Installation

All seams, joints, penetrations, and duct to hood collar connections shall have a liquid-tight external weld.

An inlet transition is furnished to match the inlet duct size. The inlet transition is furnished with a listed duct access door for inspection and cleaning.

Units intended for indoor mounting are provided with a UL 762 listed exhaust fan with outlet mounting flange. Outlet ductwork from the exhaust fan is required to be per the above mentioned methods unless otherwise specified by the local authority having jurisdiction (AHJ).

Electrical Connections

Electrical wiring must conform to the equipment data plate information and to the NEC and local code requirements.

Motor

This unit is furnished with a remote-mounted motor starter and an ON/OFF disconnect switch mounted adjacent to the fan and factory-wired to the fan motor.

A 3-phase electrical supply must be field wired to the motor starter and from the motor starter to the ON/OFF disconnect switch.

Refer to the applicable fan installation manual for detailed instructions on wiring the fan.

Remote Status Indicator

A single phase electrical supply must be field wired to the pressure switch enclosure (located on the access side of the Triple Play housing between filter stages 2 and 3, adjacent to the exhaust fan). For wiring details, refer to the diagram on pages 8 and 9.



Fire System

This equipment is furnished with factory pre-piped fire suppression nozzles and fusible link detector brackets. The brand of the system was specified at time of order (Amerex or Ansul). Factory installation is according to the Fire System manufacturers recommendations. Field connection, tanks, controls, fusible link detectors, and commissioning is provided and installed, on site, by others. The AHJ may require additional protection.

Filter Installation (See Figure #2 on page 7)

All 4 stages of filters are shipped on a separate skid in the original factory packaging. Do not remove packaging or install filters until just prior to commissioning the unit.

Care must be taken to ensure filters are installed in the proper sequence and proper direction of airflow for filter stages 1, 2 & 3 (stage 4 carbon panels are not subject to airflow direction).

Open the access doors. Remove the filter compression plates at stages 1, 2, 3 & 4. Install filters and replace all 4 filter compression plates. Compression plates must be in place to ensure proper filter sealing integrity. Close and latch access doors.

NOTE

Access doors are on lift-off hinges and can be easily removed for more convenient filter servicing.

Filter Stage	Dimensions (inches) Description
Pre-Filter (Stage 1)	24 x 24 x 4 thick MERV 8 Pleated metal frame filter
Bag Filter (Stage 2)	24 x 24 x 22 deep MERV 14 Bag filter
Rigid Filter (Stage 3)	24 x 24 x 12 thick MERV 16 95% DOP HEPA-type filter
Carbon Panel (Stage 4)	24 x 24 x 1 thick Bonded carbon panel

NOTE

Only UL 900, Class 1 filters are approved for use in this equipment. Substitutions will void the manufacturer's warranty and the listing to UL 710. Please refer to the Maintenance section for information on ordering replacement filters.

Operation

NOTE

Prior to starting the fan, remove fan tie down straps. These are used only to prevent shipping damage. After removing the tie down straps, the fan should float freely on the spring isolators. Confirm that the installation is completed as shown in the Installation section.

Start-Up

Turn the unit on momentarily and then turn off. Remove fan drive access cover and verify proper fan wheel rotation. If rotation is backwards, reverse the fan motor electrical input leads. After verifying the proper fan wheel rotation, the unit is ready for operation.

Filter Status Indicator

As filter stages 1, 2 and 3 load with smoke and grease particles, resistance to airflow increases and the exhaust air volume decreases. Pressure switches continuously read the resistance across each filter stage. Each pressure switch is factory preset to transmit an alarm signal when that stage of filter has reached its terminal resistance and needs replacing with new filters. This terminal resistance setting is based on the filter manufacturers rating. The alarm signal lights an LED located on the face panel of the remote Filter Status Indicator Enclosure.

IMPORTANT

Replace filters immediately after the Filter Status Indicator light comes on. Failure to do so may cause a reduced exhaust air volume allowing smoke to escape into the kitchen, or may cause filters to rupture, or both. The terminal resistance for each stage of filters is factory set at the values shown below. Altering these settings without first contacting Accurex, LLC will void the manufacturer's warranty and void the UL 710 listing.

Filter Stage	Resistance Setting
1	1.2 in. wg.
2	1.0 in. wg.
3	1.7 in. wg.



Filter Replacement

Determine which stage(s) of filter needs replacing as shown by lighted LED(s) located on the face panel of the remote Filter Status Indicator Enclosure.

1. Have the correct type and quantity of filters available at the unit.
2. Turn off and lockout power to the fan.
3. Open the appropriate access door(s) and remove the filter pressure plate(s).
4. Remove the spent filter(s) by sliding them out of the housing access door opening.
5. Replace with the proper new filter(s) making sure direction of airflow is correct.
6. Replace filter compression plate(s).
7. Close and latch access door(s).
8. Turn on power to the fan.
9. Proper filter disposal is important to the environment. Refer to local landfill codes.

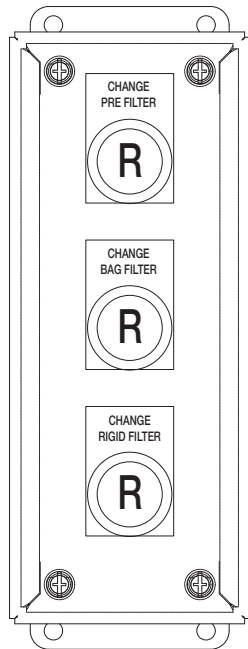

REMOTE FILTER
STATUS INDICATOR

Maintenance

Regular Scheduled Maintenance

1. Replace stage 1, 2 and 3 filter(s) immediately after the remote Filter Status Indicator LED(s) light up.
2. Replace carbon panels at the first sign of odor breakthrough.
3. Remove all filters and carbon panels and pressure wash/clean the housing interior yearly. Only use degreasers that are compatible with painted metal surfaces. Use caution so as to not damage static pressure tips, tubing or fire system nozzles and detectors. Dry the housing interior and replace Stage 1-4 filters, replace filter pressure plates, close and latch access doors.
4. Remove/open fan scroll access door and pressure wash/clean all internal surfaces of the fan every 6 months. Check sheave-belt alignment and belt tightness.

Replacement Filter/Parts Ordering

Replacement filters and carbon panels can be obtained through any source offering UL 900, Class 1 filters as specified in the Filter section under Filter Installation. As a recommendation, replacement filters are available through AirScrubbers Inc.

Phone: 919-718-5818

www.airscrubbersinc.com

Carbon Panel Replacement

Unlike particulate filters, technology has yet to develop a cost-friendly method of determining when the carbon panels need replacing. So, the industry standard is the human sniff test. As the carbon begins to lose its effectiveness, odor breakthrough gradually occurs and odor concentration increases. Based on a variety of cooking applications/installations, life of the carbon panels can range from a few months to one year. Replace carbon panels when odor breakthrough is first noticed. When replacing carbon panels, follow the instructions in the Operation section, Filter Replacement, Steps 2-10. There is no particular direction of airflow for carbon panels.



Figures

Figure #1

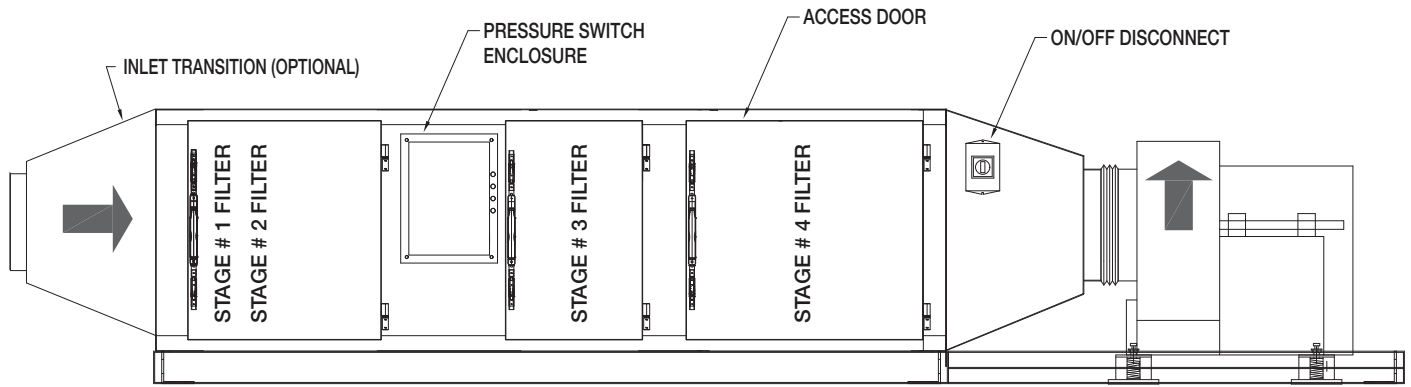

ACCESS DOOR SIDE
(Elevation View)

Figure #2

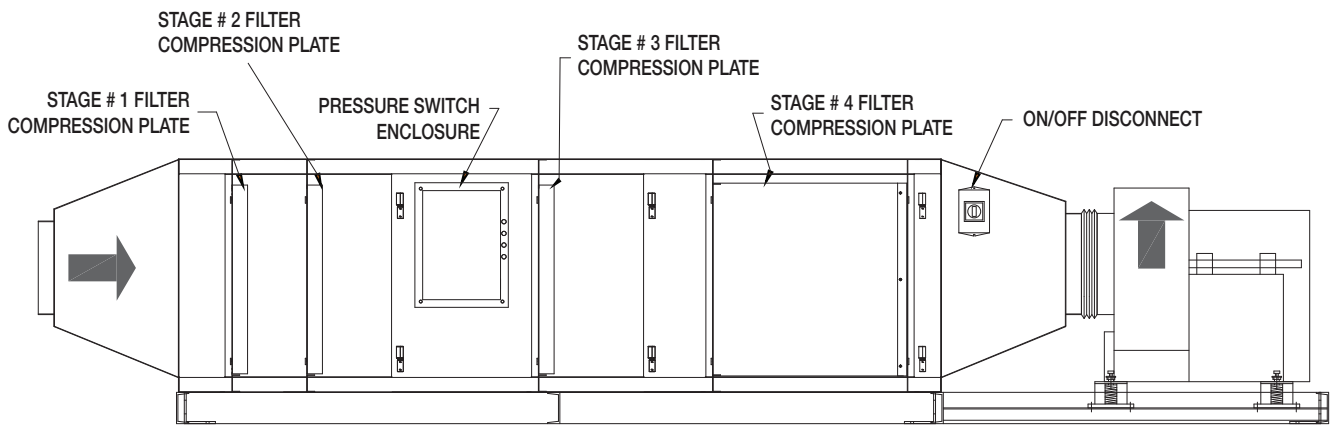

ACCESS DOORS REMOVED
(Elevation View)

Wiring Diagram

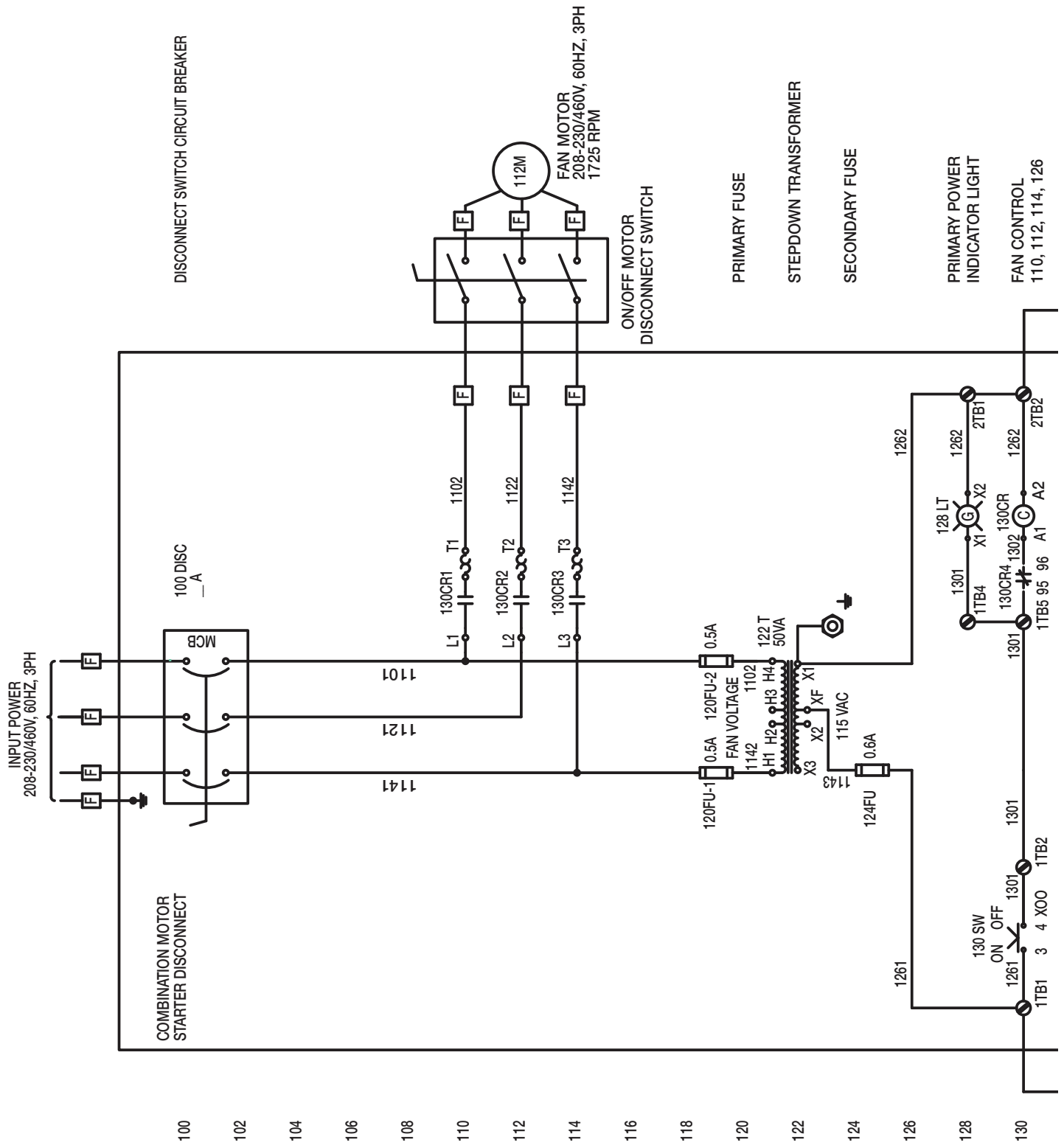

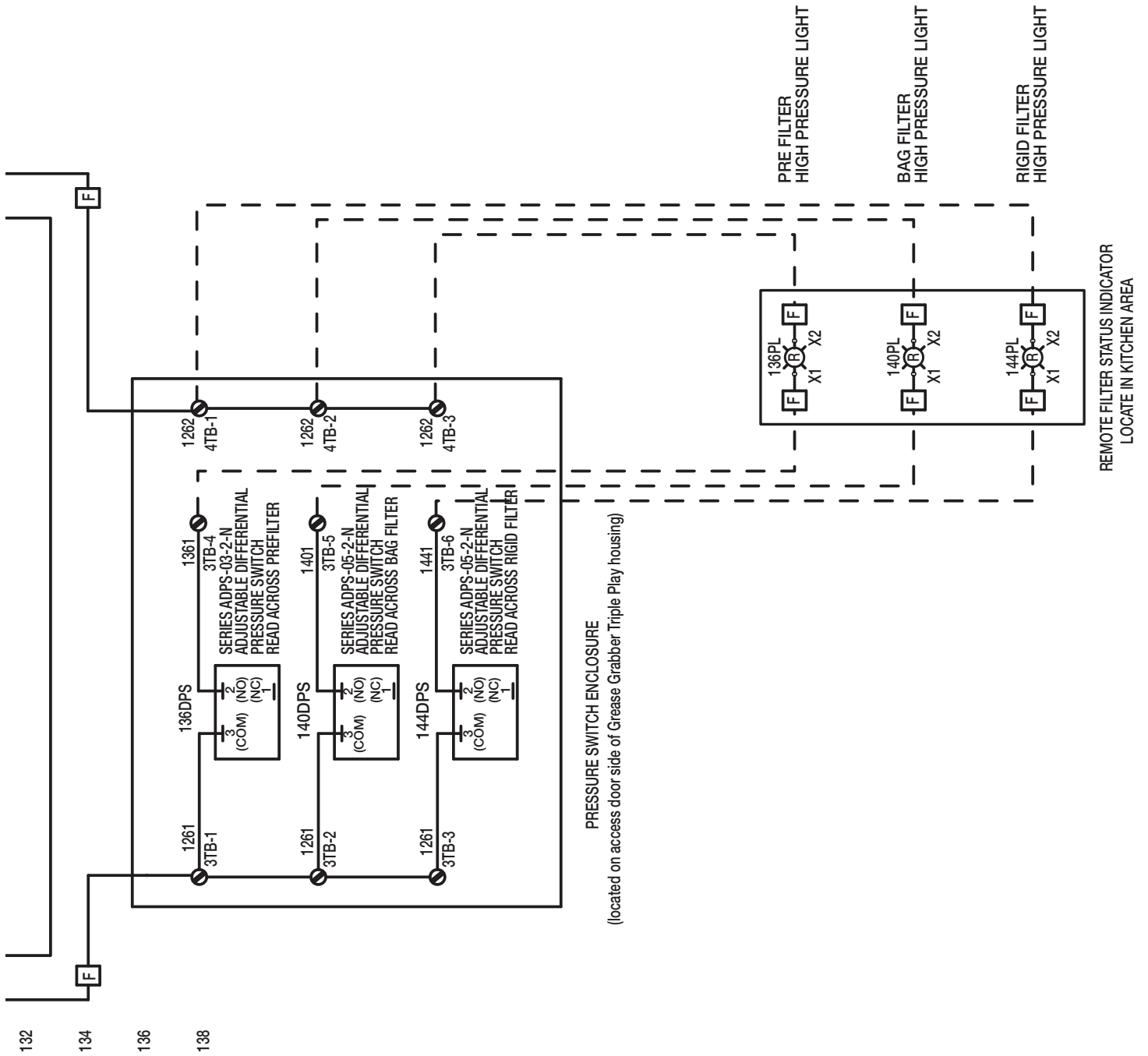

Maintenance Log

Date _____ Time _____ AM/PM
Notes: _____

Date _____ Time _____ AM/PM
Notes: _____

Date _____ Time _____ AM/PM
Notes: _____

Date _____ Time _____ AM/PM
Notes: _____

Date _____ Time _____ AM/PM
Notes: _____

Date _____ Time _____ AM/PM
Notes: _____

Date _____ Time _____ AM/PM
Notes: _____

Date _____ Time _____ AM/PM
Notes: _____

Date _____ Time _____ AM/PM
Notes: _____

Date _____ Time _____ AM/PM
Notes: _____

Date _____ Time _____ AM/PM
Notes: _____

Date _____ Time _____ AM/PM
Notes: _____

Date _____ Time _____ AM/PM
Notes: _____

Date _____ Time _____ AM/PM
Notes: _____



Date _____ Time _____ AM/PM
Notes: _____

Date _____ Time _____ AM/PM
Notes: _____

Date _____ Time _____ AM/PM
Notes: _____

Date _____ Time _____ AM/PM
Notes: _____

Date _____ Time _____ AM/PM
Notes: _____

Date _____ Time _____ AM/PM
Notes: _____

Date _____ Time _____ AM/PM
Notes: _____

Date _____ Time _____ AM/PM
Notes: _____

Date _____ Time _____ AM/PM
Notes: _____

Date _____ Time _____ AM/PM
Notes: _____

Date _____ Time _____ AM/PM
Notes: _____

Date _____ Time _____ AM/PM
Notes: _____

Date _____ Time _____ AM/PM
Notes: _____

Date _____ Time _____ AM/PM
Notes: _____



Warranty

Accurex warrants this equipment to be free from defects in material and workmanship for a period of one year from the shipment date. Any units or parts which prove to be defective during the warranty period will be replaced at our option when returned to our factory, transportation prepaid. Motors are warranted by the motor manufacturer for a period of one year. Should motors furnished by Accurex prove defective during this period, they should be returned to the nearest authorized motor service station. Accurex will not be responsible for any removal or installation costs.

As a result of our commitment to continuous improvement, Accurex reserves the right to change specifications without notice.



P.O. Box 410 Schofield, WI 54476
Phone: 800.333.1400 Fax: 715.241.6191
www.accurex-systems.com