

Installation, Operation and Maintenance Manual

Please read and save these instructions for future reference. Read carefully before attempting to assemble, install, operate or maintain the product described. Protect yourself and others by observing all safety information. Failure to comply with instructions could result in personal injury and/or property damage!



Model XRUBS Ultimate Steel Grease Fan

Model XRUBS is a belt drive upblast centrifugal exhaust fan. These fans are specifically designed for high grease applications. Fans are Miami-Dade approved for high-velocity hurricane zones, NOA# 12-0501.04.

Performance capabilities range up to 6,800 cfm (11,500 m³/hr) and up to 3.25 in. wg (810 Pa) of static pressure. The maximum continuous operating temperature is 400°F (204.4°C). Model XRUBS is available in nine sizes, 140-200HP with nominal wheel diameter ranging from 14 to 20 inches (356 to 508 mm). Each fan shall bear a permanently affixed manufacturer's engraved metal nameplate containing the model number and individual serial number.

General Safety Information

Only qualified personnel should install this fan. Personnel should have a clear understanding of these instructions and should be aware of general safety precautions. Improper installation can result in electric shock, possible injury due to coming in contact with moving parts, as well as other potential hazards. Other considerations may be required if high winds or seismic activity is present. If more information is needed, contact a licensed professional engineer before moving forward.

- Follow all local electrical and safety codes, as well as the National Electrical Code (NEC) and the National Fire Protection Agency (NFPA), where applicable. Follow the Canadian Electric Code (CEC) in Canada.
- The rotation of the wheel is critical. It must be free to rotate without striking or rubbing any stationary objects.
- Motor must be securely and adequately grounded.
- Do not spin fan wheel faster than max cataloged fan RPM. Adjustments to fan speed significantly affects motor load. If the fan RPM is changed, the motor current should be checked to make sure it is not exceeding the motor nameplate amps.
- Do not allow the power cable to kink or come in contact with oil, grease, hot surfaces or chemicals. Replace cord immediately if damaged.
- Verify that the power source is compatible with the equipment.
- Never open access doors to a duct while the fan is running.

DANGER

Always disconnect, lock and tag power source before installing or servicing. Failure to disconnect power source can result in fire, shock or serious injury.

CAUTION

When servicing the fan, motor may be hot enough to cause pain or injury. Allow motor to cool before servicing.

CAUTION

Precaution should be taken in explosive atmospheres.

DANGER

Pour écarter les risques d'incendie, de choc électrique ou de blessure grave, veiller à toujours débrancher, verrouiller et étiqueter la source de courant avant l'installation ou l'entretien.

ATTENTION

Lors de toute intervention sur la soufflante, le moteur peut être suffisamment chaud pour provoquer une douleur voire une blessure. Laisser le moteur refroidir avant toute maintenance.

ATTENTION

Faire preuve de précaution dans les atmosphères explosives.

Table of Contents

General Safety Information	1
Receiving, Unpacking, Handling, Storage, Inspection and Maintenance During Storage	
Removing from Storage	2-3
Dimensional Data	4
Installation	
Typical Roof Mounting	4-5
Commercial Kitchen	5
Grease Trap	6
UL Listed Emergency Smoke Control	6
Mounting for Severe Duty.	7
Pre-Starting Checks	8-9
Operation.	9
Inspection	9
Maintenance	10
Belt and Bearing Maintenance	10-11
Recommended Bearing Lubrication.	11
Fan Inlet Conditions	11
Troubleshooting.	12
Parts List	13
Maintenance Log.	14-15
Our Commitment.	16

Receiving

Upon receiving the product, check to ensure all items are accounted for by referencing the delivery receipt or packing list. Inspect each crate or carton for shipping damage before accepting delivery. Alert the carrier of any damage detected. The customer will make a notation of damage (or shortage of items) on the delivery receipt and all copies of the bill of lading which is countersigned by the delivering carrier. If damaged, immediately contact your Accurex Representative. Any physical damage to the unit after acceptance is not the responsibility of Accurex, LLC.

Unpacking

Verify that all required parts and the correct quantity of each item have been received. If any items are missing, report shortages to your local representative to arrange for obtaining missing parts. Sometimes it is not possible that all items for the unit be shipped together due to availability of transportation and truck space. Confirmation of shipment(s) must be limited to only items on the bill of lading.

Handling

When lifting the unit onto the roof, use either the four lifting points on the drive frame or the two lifting points on the bearing plate if present, see Figure 1 for lifting points. Access to the drive frame is accomplished by removing the screws pointed out in Figure 2. The cover can then be removed and placed on a flat surface in an area protected from strong winds.

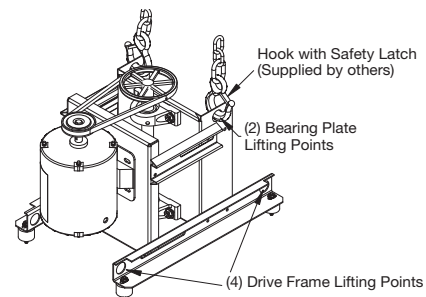

Figure 1

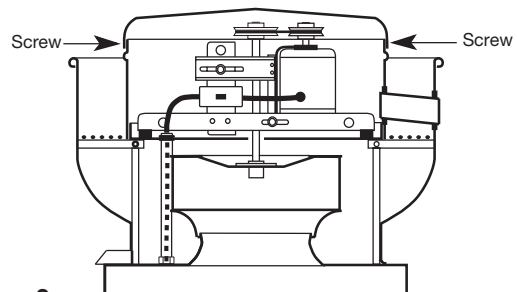

Figure 2



When the XRUBS unit is on the roof, move fan to desired location using lifting points and fasten securely according to mounting details outlined in the Installation section pertaining to your application. Shims may be necessary depending upon roofing material thickness.

IMPORTANT

Do not lift by the fan hood. Avoid lifting fans in a way that will bend or distort fan parts. Never pass slings or timbers through the venturi of fan. Fans with special coatings or paints must be protected in handling to prevent damage.

The motor amperage and voltage ratings must be checked for compatibility to supply voltage prior to final electrical connection. Wiring must conform to local and national codes. Consult local code authorities for specific requirements.

Storage

Fans are protected against damage during shipment. If the unit cannot be installed and operated immediately, precautions need to be taken to prevent deterioration of the unit during storage. The user assumes responsibility of the fan and accessories while in storage. Accurex, LLC will not be responsible for damage during storage. These suggestions are provided solely as a convenience to the user.

Indoor - The ideal environment for the storage of fans and accessories is indoors, above grade, in a low humidity atmosphere which is sealed to prevent the entry of blowing dust, rain or snow. Temperatures should be evenly maintained between 30° to 110°F (-1° to 43°C) (wide temperature swings may cause condensation and “sweating” of metal parts). All accessories must be stored indoors in a clean, dry atmosphere.

Remove any accumulations of dirt, water, ice, or snow and wipe dry before moving to indoor storage. To avoid “sweating” of metal parts, allow cold parts to reach room temperature. To dry parts and packages use a portable electric heater to get rid of any moisture buildup. Leave coverings loose to permit air circulation and to allow for periodic inspection.

The unit should be stored at least 3½ inches (89 mm) off the floor on wooden blocks covered with moisture proof paper or polyethylene sheathing. Aisles between parts and along all walls should be provided to permit air circulation and space for inspection.

Outdoor - Fans designed for outdoor applications may be stored outdoors, if absolutely necessary. Roads or aisles for portable cranes and hauling equipment are needed.

The fan should be placed on a level surface to prevent water from leaking into the fan. The fan should be elevated on an adequate number of wooden blocks so that it is above water and snow levels and has

enough blocking to prevent it from settling into soft ground.

Locate parts far enough apart to permit air circulation, sunlight and space for periodic inspection. To minimize water accumulation, place all fan parts on blocking supports so that rain water will run off.

Do not cover parts with plastic film or tarps as these cause condensation of moisture from the air passing through heating and cooling cycles.

Fan wheels should be blocked to prevent spinning caused by strong winds.

Inspection and Maintenance During Storage

While in storage, inspect fans once per month. Keep a record of inspection and maintenance performed.

If moisture or dirt accumulations are found on parts, the source should be located and eliminated. At each inspection, rotate the wheel by hand ten to fifteen revolutions to distribute lubricant in motor and bearings. If paint deterioration begins, consideration should be given to touch-up or repainting. Fans with special coatings may require special techniques for touch-up or repair.

Machined parts coated with rust preventive should be restored to good condition promptly if signs of rust occur. Immediately remove the original rust preventive coating with petroleum solvent and clean with lint-free cloths. Polish any remaining rust from surface with crocus cloth or fine emery paper and oil. Do not destroy the continuity of the surfaces. Thoroughly wipe clean with Tectyl® 506 (Ashland Inc.) or the equivalent. For hard to reach internal surfaces or for occasional use, consider using Tectyl® 511M Rust Preventive, WD-40® or the equivalent.

Removing from Storage

As fans are removed from storage to be installed in their final location, they should be protected and maintained in a similar fashion until the fan equipment goes into operation.



Dimensional Data

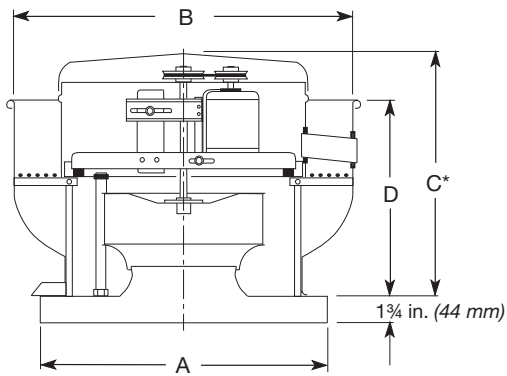

Fan Size	A	B	*C	D	Roof Opening	^Approx. Weight
140, 140HP	26 (660)	28 ⁷ / ₈ (733)	29 ³ / ₄ (756)	19 ³ / ₈ (492)	18 ¹ / ₂ (470)	125 (57)
160, 160HP, 160XP						131 (59)
180, 180HP	30 (762)	35 ³ / ₈ (899)	28 ⁵ / ₈ (727)	21 (553)	20 ¹ / ₂ (521)	190 (86)
200, 200HP						213 (97)

- All dimensions are in inches (*millimeters*).
- Dimension "A" is the inside dimension of the curb cap. The roof curb should be 1¹/₂ in. (38 mm) less than the curb cap to allow for roofing and flashing.
- * Dimension "C" may vary depending on motor size.
- ^ Approximate weight shown in pounds (*kilograms*) reflects the largest cataloged Open Drip Proof motor. Approximate weight does not include the roof curb.
- Roof opening is a square dimension.

Installation

IMPORTANT

Installation, troubleshooting and parts replacement are to be performed only by qualified personnel. Consult and follow NFPA 96 recommendations. NFPA 96 instructions supercede this document.

Typical Roof Mounting Installation

1. On the roof surface, cut an appropriate sized hole and follow manufacturer's instructions on curb installation. Caulk and flash the curb to ensure a water tight seal.
2. Remove motor cover. Access to the motor compartment is accomplished by removing the screws as shown in Figure 2, page 2. The cover can then be removed and placed on a flat surface in an area protected from strong winds.
3. On the drive frame use the lifting lugs to lift and place the unit on top of roof curb. Refer to Figure 1, page 2.
4. Secure fan to curb.
5. Verify power line wiring is de-energized before connecting fan motor to power source.
6. For commercial kitchen applications, the electrical supply must enter the motor compartment through the breather tube. For other non-flammable applications, the electrical supply should also be routed through the breather tube. Consult local code authorities for specific requirements.
7. Connect power supply wiring to the motor as indicated on the motor nameplate or terminal box cover. Check the power source for compatibility with the requirements of your equipment.
8. Check fan wheel for free rotation and recenter if necessary.
9. Check all fasteners for tightness.
10. Mount and wire safety disconnect switch under motor cover. Wire control switches at ground level, refer to Figure 3.

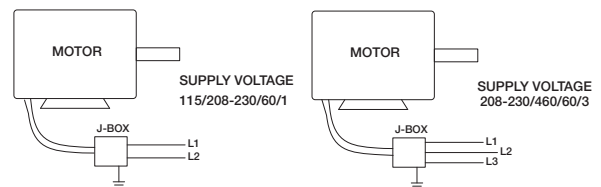

Figure 3 - Typical Wiring Diagram

11. Replace motor cover.
12. A drain trough is provided on all XRUBS fans for single-point drainage of water and residue. Some means for collection of this residue must be provided, either a container directly under the trough or use of an adapter and pipe to carry the



residue to a remote collection point. An optional grease trap with water separator baffle is available from your Accurex representative.

13. A clean-out port and hinged base are also provided on all XRUBS's. They aid the cleaning process through additional access to the wheel. The XRUBS is designed for the worst cooking conditions, such as char broilers, solid fuel cooking or oriental cooking.

Table 1 shows the suggested Exhaust System Inspection Schedule published in NFPA 96.

Table 1: Exhaust System Inspection Schedule

Type or Volume of Cooking	Frequency Check
Systems serving solid fuel cooking operations	Monthly
Systems serving high-volume cooking operations, such as 24 hour cooking, char broiling, or wok cooking	Quarterly
Systems serving moderate-volume cooking operations	Semiannually
Systems serving low-volume cooking operations, such as churches, day camps, seasonal business, or senior centers	Annually

14. Clean-Out Port: Position the clean-out port so it is on the side of unit when hinged open, see Figure 4.



Figure 4

15. Hinged Base: During installation of the hinged base, it is important not to allow the fan to go beyond 90°, see Figure 5.



Figure 5

Commercial Kitchen Installation

Commercial kitchen installations must comply with NFPA 96. Check local and national codes for these installations, and consult local code authorities for other specific requirements.

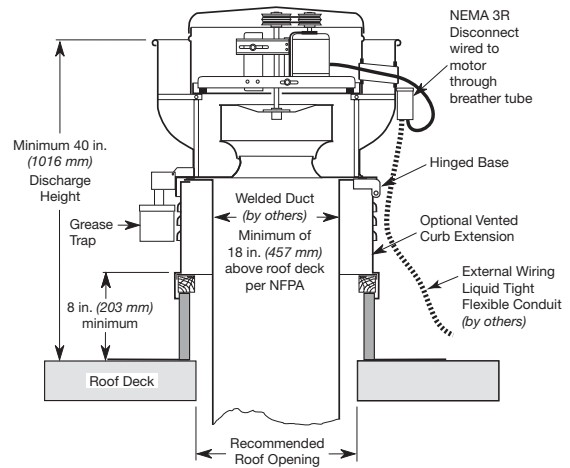

Figure 6 - Typical Roof Mounting Installation

- The size of the duct must be equal to or larger than the inlet opening of the fan.
- Secure fan to curb using a minimum of eight lag screws, metal screws or other suitable fasteners.
- To comply with NFPA 96, the fan discharge must be a minimum of 40 in. (1016 mm) above the roof surface and a minimum of 10 ft. (3048 mm) from any building air intake.
- Per NFPA 96, ductwork to an upblast discharge exhaust fan must be constructed of and supported by carbon steel not less than No. 16 MSG (1.52 mm) or stainless steel not less than No. 18 MSG (1.21 mm) in thickness. Duct must also extend a minimum of 18 in. (457 mm) above the roof surface.
- Ensure that a minimum of 500 ft/min of air velocity through the duct is maintained per NFPA 96, clause 8.2.1.1, 2014 edition and UL 762, Issue #7, clause 6.2, October 14, 2013.
- The following accessories may be required by NFPA 96 depending upon installation: Grease Trap and Vented Curb.

WARNING

Minimum duct velocities must be maintained in kitchen exhaust applications. If a speed controller is used, ensure compliance with all applicable codes.

Representation of
UL Listed
Power Ventilator
Restaurant
Exhaust
Appliances
label

UL LISTED

Power Ventilator
Restaurant Exhaust Appliances
13G3
Maximum Operating Temperature
400°F

—Important—

ELECTRICAL – If fan motor is $\frac{1}{2}$ thermally protected, remote overload protection must be installed having adequate rating as to voltage, frequency, horsepower, and full load current per phase. Where connected to a circuit protected by fuses, use time delay fuses. For supply connection use wires rated for at least 90°C (194°F).

INSTALLATION – When connecting electrical power to this fan, do not restrict motor movement for possible future belt or wheel adjustment.

Must be installed in accordance with the requirements to NFPA 96 or must have minimum clearances of zero inches to non-combustibles, 3 inches to limited combustibles, 18 inches to combustibles.

CAUTION – Mount with the lowest moving part at least 8 ft (2.5m) above floor or grade level. Not required on roof mounted ventilators or duct mounted ventilators provided with belt guards.

ATTENTION – Monter la pièce mobile la plus basse à au moins 2.5 m au-dessus du niveau du sol. Non requis pour les ventilateurs montés sur un toit ou pour les ventilateurs montés sur gaine avec protège-courroie.

461546



Grease Trap Installation

Polypropylene grease trap is designed to collect grease residue and avoid drainage onto roof surface. Follow all local codes, as well as the National Fire Protection Agency (NFPA) where applicable.

NFPA 96: Upblast fans shall have a drain directed to a readily accessible and visible grease receptacle not to exceed 1 gal. (3.8L)

Refer to Document 476376 - Grease Trap Installation, Operation and Maintenance Manual for parts listing and specific installation instructions.

Grease Trap Maintenance

Regular inspection of grease trap is recommended. Depending on the amount of grease discharged through the fan, the grease trap should be cleaned regularly to ensure proper operation.

- Check grease absorber (if included) every month. Replace grease absorber after every cleaning and/or as needed between cleanings.
- Replacement grease absorbers (P/N 476084) can be ordered from your local Representative.

UL Listed Emergency Smoke Control Installation

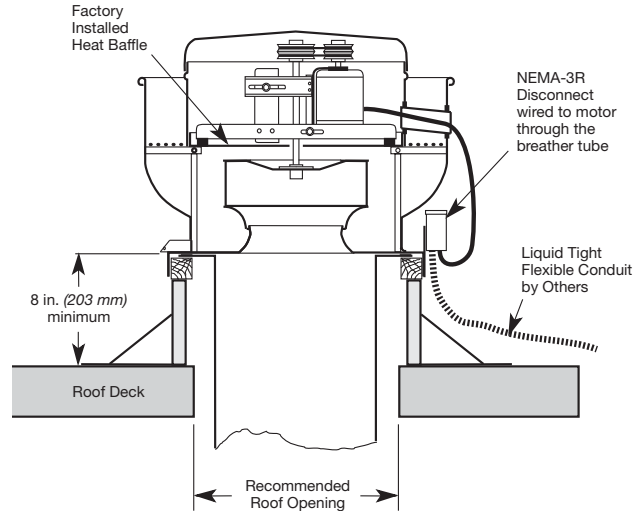

Figure 7 - Typical Roof Mounting Installation

Electrical Connection

For belt drive units in emergency smoke removal installations, the motor's amperage and voltage rating must be checked for compatibility to the supply voltage prior to final electrical connection. Also, the motor itself cannot have thermal overload protection.

The electrical supply must enter the motor compartment through the breather tube and the disconnect must be mounted outside the fan's motor compartment. Emergency smoke removal fans may also require an isolated power supply so that if power is cut to the building in the event of a fire, the fan will continue to operate.

Check the local and national electrical codes for emergency smoke removal fans, and consult local code authorities for your specific requirements.

Representation of
UL Listed
Power Ventilator
For Smoke
Control Systems
76YG
label

	-Important-
	<p>ELECTRICAL - If fan motor is NOT thermally protected, remote overload protection must be installed having adequate rating as to voltage, frequency, horsepower, and full load current per phase. Where connected to a circuit protected by fuses, use time delay fuses. For supply connection use wires rated for at least 90°C (194°F).</p> <p>INSTALLATION - When connecting electrical power to this fan, do not restrict motor movement for possible future belt or wheel adjustment.</p> <p>CAUTION - Mount with the lowest moving part at least 8 ft (2.5m) above floor or grade level. Not required on roof mounted ventilators or duct mounted ventilators provided with belt guards.</p> <p>ATTENTION - Monter la pièce mobile la plus basse à au moins 2,5 m au-dessus du niveau du sol. Non requis pour les ventilateurs montés sur un toit ou pour les ventilateurs montés sur gaine avec protège-courroie.</p>
	454075



Mounting for Severe Duty Installations

IMPORTANT

Only qualified installers should perform this work. Manufacturer assumes no liability for damages resulting from installation.

Installation instructions for seismic ratings are only recommendations. Final design must be determined by Structural Engineer of Record (SEOR) including requirements for curb construction, mounting of unit to curb and mounting of curb to structure.

Fan to Curb Mounting

5/16-inch (7.9 mm) self-drilling fasteners are to be installed on each side of fan with one fastener 4-inches (102 mm) from each edge and one fastener in the center. Fasteners are to be equally spaced.

All fasteners must be installed through the curb cap of the fan, the hinged base, and the curb. All fasteners must be reinstalled after each time the fan is hinged open. Refer to drawings.

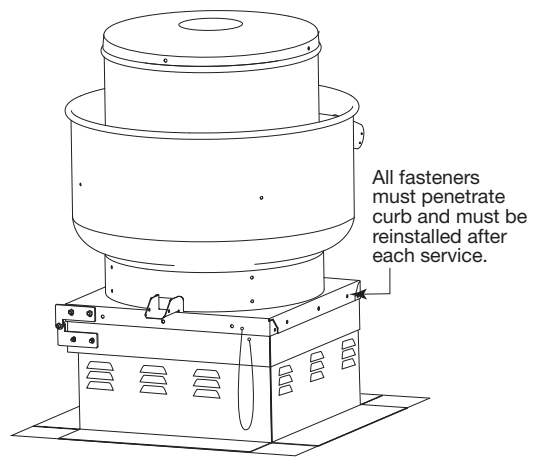
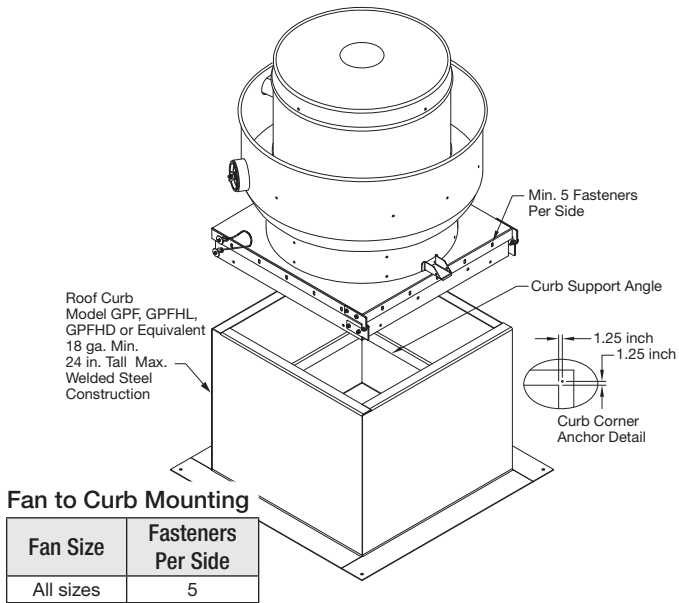

Fan to Curb Mounting

Fan Size	Fasteners Per Side
All sizes	5

Curb to Deck Mounting

Fasteners need to be located on two opposite ends of the curb.

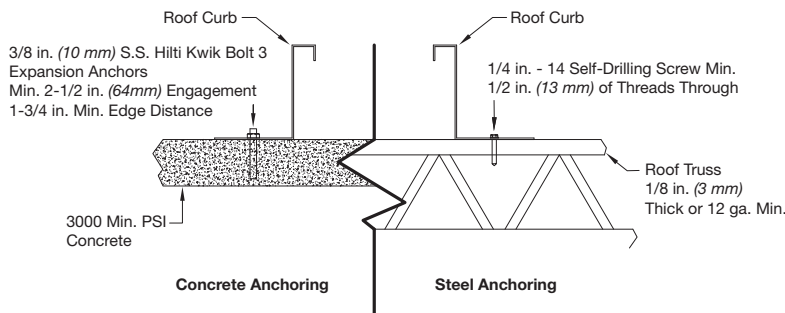

High Wind Ratings

	Fan Size	Curb Cap Size inches (millimeters)	Self-Drilling Screw Size*	Fasteners Per Side	Total Fasteners
Concrete	140 - 160	17x17 to 22x22 (432x432 to 559x559 mm)	3/8 in. (10 mm)	5	20
	180 - 200	26x26 to 40x40 (660x660 to 1016x1016 mm)		7	28
Steel	140 - 160	17x17 to 22x22 (432x432 to 559x559 mm)	1/4 - 14 (6.4 mm)	5	20
	180 - 200	26x26 to 40x40 (660x660 to 1016x1016 mm)		7	28

All dimensions in inches (millimeters).

Seismic Ratings

Fan Size	Fasteners per side	Total Fasteners
140 - 160	5	20
180 - 200	7	28
140 - 160	5	20
180 - 200	7	28



Pre-Starting Checks

DANGER

Disconnect and secure to the “off” position all electrical power to the fan prior to inspection or servicing. Failure to comply with this safety precaution could result in serious injury or death.

DANGER

Pour écarter les risques de blessure grave ou de mort, débrancher et verrouiller l'alimentation électrique en position « Arrêt » avant tout contrôle ou entretien.

1. Check all fasteners and setscrews for tightness. The wheel should rotate freely and be aligned as shown in Figure 8.

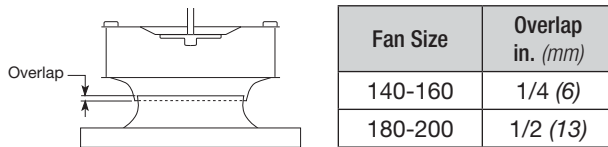
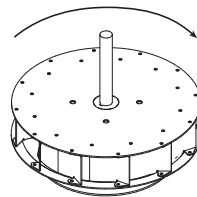

Figure 8

2. Wheel position is preset and the unit is test run at the factory. Movement may occur during shipment and realignment may be necessary.
3. Centering can be accomplished by loosening the bolts holding the drive frame to the vibration isolators and repositioning the drive frame.
4. Wheel and inlet cone overlap can be adjusted by loosening the setscrews in the wheel and moving the wheel to the desired position.
5. Fan RPM should be checked and verified with a tachometer.
6. Check wheel rotation (viewing from the shaft side) by momentarily energizing the unit. Rotation should be clockwise when viewed from the top of the fan and correspond to the rotation decal on the unit, see Figure 9.

If wheel rotation is incorrect, reverse two of the wiring leads or check motor wiring for single phase.



Clockwise Rotation

Figure 9

WARNING

Correct direction of wheel rotation is critical. Reversed rotation will result in poor air performance, motor overloading and possible motor burnout.

AVERTISSEMENT

La turbine doit impérativement tourner dans le bon sens. Une rotation en sens inverse entraînerait de mauvaises performances de soufflage, une surcharge du moteur voire un grillage du moteur.

7. Always loosen tension enough to install belts without stretching, see Figure 10.

Do not force belt(s). Forcing the belts will break the cords and cause belt failure.

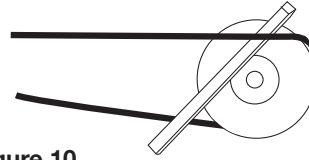

Figure 10

8. For units with two groove pulleys, adjust so the tension is equal in both belts.
9. If adjustments are made, it is very important to check the pulleys for proper alignment. Misaligned pulleys lead to excessive belt wear, vibration, noise and power loss, see Figure 11.

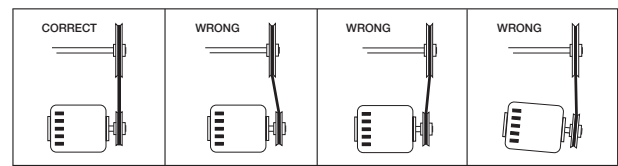

Figure 11

IMPORTANT

The fan has been checked for mechanical noises at the factory prior to shipment. If mechanical noise should develop, suggested corrective actions are offered in the Troubleshooting section.

10. For all XRUBS units, belt tension can be adjusted by loosening four fasteners on the drive frame, see Figure 12. The motor plate slides on the slotted adjusting arms and drive frame angles in the same manner.

Four (4) fasteners in total.

Identical fasteners on opposing side must also be loosened.

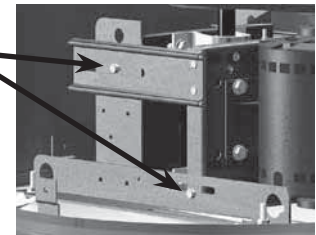

Figure 12



11. Belt tension should be adjusted to allow 1/64 inch (0.397 mm) of deflection per inch of belt span. For example, a 15 inch (381 mm) belt span should have 15/64 inch (0.234 mm) (or about 1/4 inch (6 mm)) of deflection with moderate thumb pressure at mid-point between pulleys, see Figure 13.

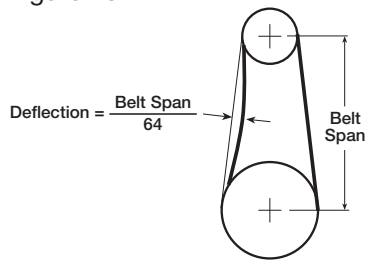

Figure 13

IMPORTANT

Over tightening will cause excessive bearing wear and noise. Too little tension will cause slippage at startup and uneven wear.

12. The adjustable motor pulley is factory set for the RPM specified. Speed can be increased by closing or decreased by opening the adjustable motor sheave. Two groove variable pitch pulleys must be adjusted an equal number of turns open or closed.
13. Any increase in speed represents a substantial increase in the horsepower required by the unit.
14. Motor amperage should always be checked to avoid serious damage to the motor when speed is varied.

Operation

1. Before starting up or operating fan, check all fasteners for tightness. In particular, check the setscrews in wheel hub and pulleys.
2. While in the OFF position or before connecting the fan to power, turn the fan wheel by hand to be sure it is not striking the venturi or any obstacle.
3. Start the fan and shut it off immediately to check rotation of the wheel with directional arrow in the motor compartment, see Figure 9.
4. When the fan is started, observe the operation and check for any unusual noises.
5. With the system in full operation and all ductwork attached, measure current input to the motor and compare with the nameplate rating to determine if the motor is operating under safe load conditions.
6. Keep inlets and approaches to fan clean and free from obstruction.

IMPORTANT

Adjust (tighten) belt tension after the first 24-48 hours of operation.

Inspection

Inspection of the fan should be conducted at the first 30 minute and 24 hour intervals of satisfactory operation.

30 Minute Interval - Inspect bolts, setscrews and motor mounting bolts. Adjust and tighten as necessary.

24 Hour Interval - Check all internal components. Inspect belt alignment and tension. Adjust and tighten as necessary.

Maintenance

DANGER
Disconnect and secure to the “off” position all electrical power to the fan prior to inspection or servicing. Failure to comply with this safety precaution could result in serious injury or death.
DANGER
Pour écarter les risques de blessure grave ou de mort, débrancher et verrouiller l’alimentation électrique en position « Arrêt » avant tout contrôle ou entretien.
WARNING
This unit should be made non-functional when cleaning the wheel or housing (fuses removed, disconnect locked off).
AVERTISSEMENT
L’appareil doit être rendu non opérationnel lors du nettoyage de la turbine ou du caisson (fusibles retirés, sectionneur verrouillé).

Once the fan has been put into operation, a periodic maintenance program should be set up to preserve the reliability and performance of the fan. Installation and maintenance are to be performed only by qualified personnel who are familiar with local codes and regulations and who are experienced with this type of equipment.

Motor maintenance is generally limited to cleaning and lubrication (where applicable). Cleaning should be limited to exterior surfaces only. Removing dust buildup on motor housing ensures proper motor cooling.

Greasing of motors is only intended when fittings are provided. Many fractional horsepower motors are permanently lubricated and should not be lubricated after installation. Motors supplied with grease fittings should be greased in accordance with manufacturers’ recommendations. Where motor temperatures do not exceed 104°F (40°C), the grease should be replaced after 2,000 hours of running time as a general rule.

Wheels require strong attention when moving air in grease applications. Grease, oil and dust may accumulate causing an imbalance. When this occurs, the wheel and housing should be cleaned to ensure smooth and safe operation.

All fasteners should be checked for tightness each time maintenance checks are performed prior to restarting unit.

A proper maintenance program will help these units deliver years of dependable service.

Belt and Bearing Maintenance

1. Belts tend to stretch after a period of time. They should be checked periodically for wear and tightness. When replacing belts, use the same type as supplied with the unit.
2. Matched belts should always be used on units with multi-groove pulleys.
3. For belt replacement, loosen the tensioning device enough to allow removal of the belt by hand. Do not force belts on or off. This may cause cords to break leading to premature belt failure.
4. Once installed, adjust belts as shown in “Pre-Starting Checks.”
5. To ensure tightness, check pulley setscrews. Proper keys must be in keyways.
6. Fan RPM should not be readjusted. Only use pulleys of identical size and type when replacing pulleys.
7. On XRUBS fans, the standard cast pillow block bearings are factory lubricated and are provided with external grease fittings. Annual lubrication is recommended, or more frequently if needed (see Table 2 on page 11). Do not over-grease. Use only one or two shots of lubricant with a hand gun. Maximum hand gun rating is 40 psi. Rotate bearings during lubrication where good safety practice permits. Caution should be employed to prevent over packing or contamination.
8. Units installed in hot, humid or dirty locations should be equipped with special bearings. These bearings will require frequent lubrication. Caution should be employed to prevent over packing or contamination.
9. Grease fittings should be wiped clean. The unit should be in operation while lubricating bearings. Extreme care should be used around moving parts.
10. Grease should be pumped in very slowly until a slight bead forms around the seal. A high grade lithium base grease should be used. Refer to Table 3, page 11.
11. During the first few months of operation check bearing setscrews periodically to ensure tightness.
12. When installing fans for commercial kitchen applications, follow NFPA 96 for cleaning fans.
13. Grease containers must be emptied at regular intervals to prevent overflow.
14. If unit is to be left idle for an extended period, remove belts and store in a cool, dry place to avoid premature belt failure.



Recommended Bearing Lubrication Frequency in Months

If unusual environment conditions exist, such as extreme temperature, moisture or contaminants, more frequent lubrication is required.

A good quality lithium base grease, conforming to NLGI Grade 2 consistency, such as those listed in Table 3.

Table 2: Suggested Fan Bearing Lubrication Intervals

Interval (months)	Type of Service
1 to 3	Heavy duty in dirty, dusty locations; high ambient temperatures; moisture laden atmosphere; vibration.
3 to 6	12 to 24 hours per day, heavy duty, or if moisture is present
6 to 12	8 to 16 hours per day in clean, relatively dry atmosphere
12 to 18	Infrequent operation or light duty in clean atmosphere

Table 3: Grease Manufacturers

Manufacturer	Grease (NLGI #2)
U.S. Electric Motors	Grease No. 83343
Chevron U.S.A. Inc	Chevron SRI Grease #2
Mobil Oil Corporation	Mobilith
	Mobil 532
Texaco, Inc.	Premium BRB #2
	Texaco Multifak #2
Amoco Oil Co.	Rykon Premium #2
Exxon	Unirex N2
Shell	B Shell Alvania #2

Fan Inlet Connections

In order to assure proper fan performance, caution must be exercised in fan placement and connection to the ventilation system. Obstructions, transitions, poorly designed elbows, improperly selected dampers, etc., can cause reduced performance, excessive noise and increased mechanical stress. For performance to be as published, the system must provide uniform and stable airflow into the fan.

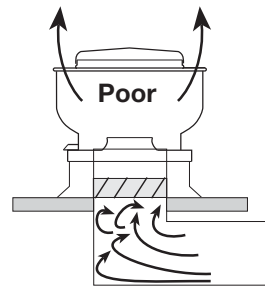

Dampers must open fully. Use motorized dampers in low airflow applications to reduce losses.

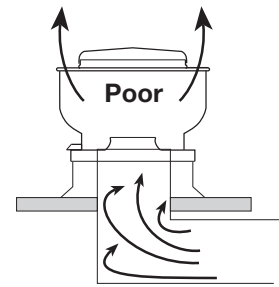

Avoid sharp turns or entrance conditions which cause uneven flow. Use turning vanes in elbows to reduce adverse effects.

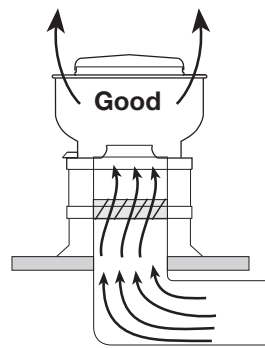

Provide uniform airflow at fan inlet and through the damper to assure optimum performance. The curb cap should be three wheel diameters from the radius. Use turning vanes in duct when possible.

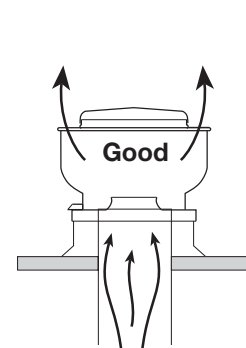

Provide uniform airflow at fan inlet to assure optimum performance.

Troubleshooting

WARNING

Before taking any corrective action, make certain unit is not capable of operation during repairs.

AVERTISSEMENT

Avant d'entreprendre toute action corrective, s'assurer que l'appareil ne pourra pas fonctionner durant les réparations.

PROBLEM	CAUSE	CORRECTIVE ACTION
Excessive noise or vibration	Wheel rubbing inlet	Adjust wheel and/or inlet cone. Tighten wheel hub or bearing collars on shaft.
	V-belt drive	Tighten pulleys on motor/fan shaft. Adjust belt tension. Align pulleys properly, see Figures 10 and 11, page 8. Replace worn belts or pulleys.
	Bearings	Replace defective bearing(s). Lubricate bearings. Tighten collars and fasteners.
	Wheel unbalance	Clean all dirt off wheel. Check wheel balance, rebalance in place if necessary.
	Bad bearings	Replace.
	Belts too tight or too loose	Adjust tension, see Figure 12 and 13.
	Wheel improperly aligned and rubbing	Center wheel on inlet, see Figure 8.
	Loose drive or motor pulleys	Align and tighten. See Pre-Starting Checks, pages 8 and 9.
	Foreign objects in wheel or housing	Remove objects, check for damage or unbalance.
	Fan base not securely anchored	Secure properly.
	Motor hood loose and rattling	Tighten fasteners securing motor hood.
	Defective or loose motor bearings	Replace motor with same frame size, RPM-HP.
	High horsepower	Fan
Duct system		Resize ductwork. Check proper operation of face and bypass dampers. Check filters and access doors.
Electrical supply		Check fuses/circuit breakers. Check for switches off. Check for correct supply voltage.
Fan doesn't operate	Drive	Check for broken belts. Tighten loose pulleys.
	Motor	Assure motor is correct horsepower and not tripping overload protector.
Motor overloads or overheats	Lubrication	Check for excessive or insufficient grease in the bearing.
	Mechanical	Replace damaged bearing. Relieve excessive belt tension. Align bearings. Check for bent shaft.
	Belt slippage	Adjust tension or replace bad belts, see pages 8 and 9.
	Over/Under line voltage	Contact power company.
	Incorrect wheel rotation	Check motor wiring, see Figure 3.
	Wheel RPM too high	Check drives or slow down fan by opening variable pitch pulley on motor shaft.
	Undersized motor	Check motor ratings with catalog speed and air capacity chart.
Motor wired incorrectly	Check motor wiring to wiring diagram located on fan motor.	
Reduced airflow	System resistance too high	Check system for obstruction in ductwork.
	Unit running backwards	Correct as shown in Figure 9.
	Excessive dirt buildup on wheels	Clean wheel.
	Improper wheel alignment	Center wheel on inlets, see Pre-Starting Checks, Figure 8, page 8.
	Dampers closed	Inspect and repair.
	Blocked duct/clogged filter	Clean or replace.
	Belt slippage	Replace and adjust tension.
Speed too slow	Check for correct drives.	



Parts List

Each fan bears a manufacturer's nameplate with model number and serial number embossed. This information will assist the local Accurex representative and the factory in providing service and replacement parts. Before taking any corrective action, make certain unit is not capable of operation during repairs.

CAUTION

A fan manufactured with an explosion resistant motor does not certify the entire unit to be explosion proof. Refer to UL Listing Mark for the fans approved usage.

CAUTION

La présence d'un moteur antidéflagrant sur un ventilateur ne garantit pas que tout l'appareil est antidéflagrant. Pour connaître les emplois autorisés de l'appareil, voir son marquage de conformité UL.

XRUBS Belt Drive

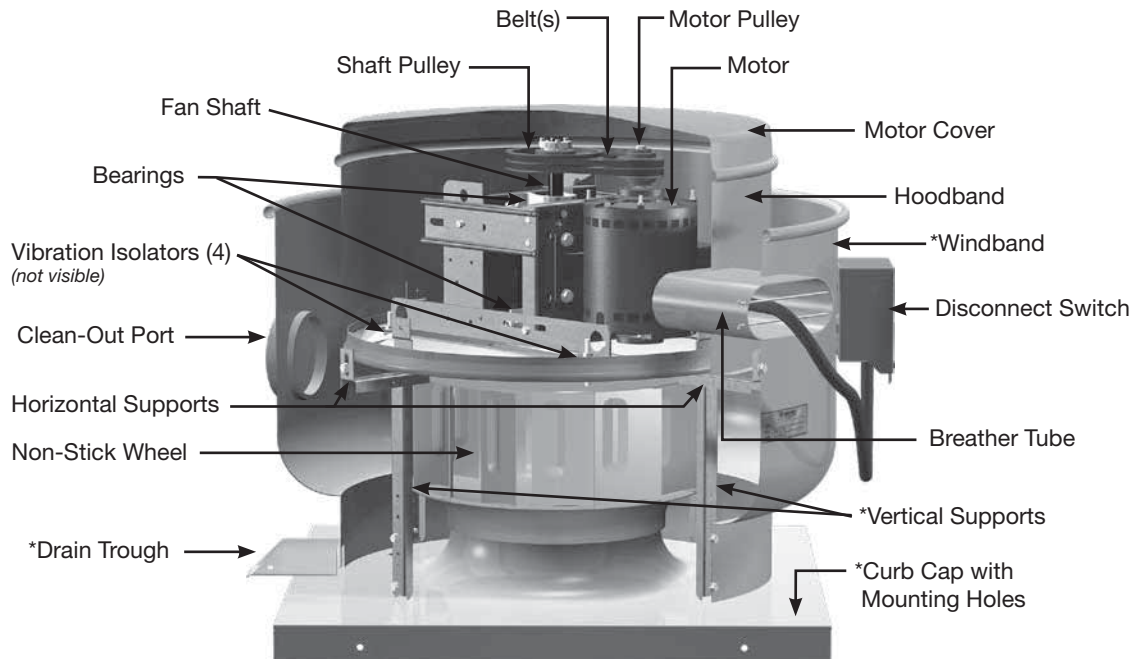

NOTE

For replacement, the windband, vertical supports, drain trough and curb cap with mounting holes comes as one complete assembly.



Maintenance Log

Date _____ Time _____ AM/PM

Notes: _____

Date _____ Time _____ AM/PM

Notes: _____

Date _____ Time _____ AM/PM

Notes: _____

Date _____ Time _____ AM/PM

Notes: _____

Date _____ Time _____ AM/PM

Notes: _____

Date _____ Time _____ AM/PM

Notes: _____

Date _____ Time _____ AM/PM

Notes: _____

Date _____ Time _____ AM/PM

Notes: _____

Date _____ Time _____ AM/PM

Notes: _____

Date _____ Time _____ AM/PM

Notes: _____

Date _____ Time _____ AM/PM

Notes: _____

Date _____ Time _____ AM/PM

Notes: _____



Maintenance Log

Date _____ Time _____ AM/PM

Notes: _____

Date _____ Time _____ AM/PM

Notes: _____

Date _____ Time _____ AM/PM

Notes: _____

Date _____ Time _____ AM/PM

Notes: _____

Date _____ Time _____ AM/PM

Notes: _____

Date _____ Time _____ AM/PM

Notes: _____

Date _____ Time _____ AM/PM

Notes: _____

Date _____ Time _____ AM/PM

Notes: _____

Date _____ Time _____ AM/PM

Notes: _____

Date _____ Time _____ AM/PM

Notes: _____

Date _____ Time _____ AM/PM

Notes: _____

Date _____ Time _____ AM/PM

Notes: _____



Our Commitment

As a result of our commitment to continuous improvement, Accurex reserves the right to change specifications without notice.

Specific Accurex product warranties are located on accurex.com within the product area tabs and in the Library under Warranties.



P.O. Box 410 Schofield, WI 54476
Phone: 800.333.1400 • Fax: 715.241.6191
Parts: 800.355.5354 • www.accurex.com