

Installation, Operation and Maintenance Manual

Please read and save these instructions for future reference. Read carefully before attempting to assemble, install, operate or maintain the product described. Protect yourself and others by observing all safety information. Failure to comply with instructions could result in personal injury and/or property damage!

Model XSED Direct Drive

Model XSED is a direct drive centrifugal sidewall exhaust fan. These fans are specifically designed for wall mounted applications. Performance capabilities range up to 6,400 cfm (10,874 m³/hr) and up to 3 in. wg (747 Pa) of static pressure. The maximum continuous operating temperature for fan sizes 098-200 is 400°F (204°C) and for fan sizes 060-095 is 160°F (71°C). XSED fans are available in 20 sizes with nominal wheel diameter ranging from 9 to 20 inches (229 mm to 508 mm) (060-200 unit sizes). Each fan shall bear a permanently affixed manufacturer's engraved metal nameplate containing the model number and individual serial number.



Model XSEB Belt Drive

Model XSEB is a belt drive centrifugal sidewall exhaust fan. These fans are specifically designed for wall mounted applications. Performance capabilities range up to 12,500 cfm (21,200 m³/hr) and up to 2.75 in. wg (685 Pa) of static pressure. The maximum continuous operating temperature is 400°F (204°C). XSEB fans are available in nineteen sizes with nominal wheel diameter ranging from 10 to 30 inches (254 to 762 mm) (099-300 unit sizes). Each fan shall bear a permanently affixed manufacturer's engraved metal nameplate containing the model number and individual serial number.

General Safety Information

Only qualified personnel should install this fan. Personnel should have a clear understanding of these instructions and should be aware of general safety precautions. Improper installation can result in electric shock, possible injury due to coming in contact with moving parts, as well as other potential hazards. Other considerations may be required if high winds or seismic activity is present. If more information is needed, contact a licensed professional engineer before moving forward.

1. Follow all local electrical and safety codes, as well as the National Electrical Code (NEC) and the National Fire Protection Agency (NFPA), where applicable. Follow the Canadian Electric Code (CEC) in Canada.
2. The rotation of the wheel is critical. It must be free to rotate without striking or rubbing any stationary objects.
3. Motor must be securely and adequately grounded.
4. Do not spin fan wheel faster than max cataloged fan RPM. Adjustments to fan speed significantly affects motor load. If the fan RPM is changed, the motor current should be checked to make sure it is not exceeding the motor nameplate amps.
5. Do not allow the power cable to kink or come in contact with oil, grease, hot surfaces or chemicals. Replace cord immediately if damaged.
6. Verify that the power source is compatible with the equipment.

7. Never open access doors to a duct while the fan is running.

DANGER
Always disconnect, lock and tag power source before installing or servicing. Failure to disconnect power source can result in fire, shock or serious injury.
CAUTION
When servicing the fan, motor may be hot enough to cause pain or injury. Allow motor to cool before servicing.
CAUTION
Precaution should be taken in explosive atmospheres.
DANGER
Pour écarter les risques d'incendie, de choc électrique ou de blessure grave, veiller à toujours débrancher, verrouiller et étiqueter la source de courant avant l'installation ou l'entretien.
ATTENTION
Lors de toute intervention sur la soufflante, le moteur peut être suffisamment chaud pour provoquer une douleur voire une blessure. Laisser le moteur refroidir avant toute maintenance.
ATTENTION
Faire preuve de précaution dans les atmosphères explosives.

Table of Contents

Receiving, Unpacking, Handling, Storage	2
Inspection and Maintenance During Storage	3
Removing from Storage	3
Dimensional Data	3
Installation	
Typical Wall Mounting	4
Commercial Kitchen	5
Mounting for Severe Duty	5
Pre-Starting Checks	6-7
Operation	7
Inspection	7
Maintenance	8
Tapered Bushing Hub Installation & Removal	9
Recommended Bearing Lubrication	10
Parts List	10
Troubleshooting	11
Our Commitment	12

Receiving

Upon receiving the product, check to ensure all items are accounted for by referencing the delivery receipt or packing list. Inspect each crate or carton for shipping damage before accepting delivery. Alert the carrier of any damage detected. The customer will make a notation of damage (or shortage of items) on the delivery receipt and all copies of the bill of lading which is countersigned by the delivering carrier. If damaged, immediately contact your Accurex Representative. Any physical damage to the unit after acceptance is not the responsibility of Accurex, LLC.

Unpacking

Verify that all required parts and the correct quantity of each item have been received. If any items are missing, report shortages to your local representative to arrange for obtaining missing parts. Sometimes it is not possible that all items for the unit be shipped together due to availability of transportation and truck space. Confirmation of shipment(s) must be limited to only items on the bill of lading.

Handling

The motor amperage and voltage ratings must be checked for compatibility to supply voltage prior to final electrical connection. For XSED/XSEB installations, the electrical supply should be routed through the conduit chase located between the mounting plate and the bottom of the motor compartment. Wiring must conform to local and national codes.

IMPORTANT

Do not lift by the fan hood. Avoid lifting fans in a way that will bend or distort fan parts. Never pass slings or timbers through the venturi of fan. Fans with special coatings or paints must be protected in handling to prevent damage.

Storage

Fans are protected against damage during shipment. If the unit cannot be installed and operated immediately, precautions need to be taken to prevent deterioration of the unit during storage. The user assumes responsibility of the fan and accessories while in storage. Accurex, LLC will not be responsible for damage during storage. These suggestions are provided solely as a convenience to the user.

Indoor - The ideal environment for the storage of fans and accessories is indoors, above grade, in a low humidity atmosphere which is sealed to prevent the entry of blowing dust, rain or snow. Temperatures should be evenly maintained between 30° to 110°F (wide temperature swings may cause condensation and “sweating” of metal parts). All accessories must be stored indoors in a clean, dry atmosphere.

Remove any accumulations of dirt, water, ice, or snow and wipe dry before moving to indoor storage. To avoid “sweating” of metal parts, allow cold parts to reach room temperature. To dry parts and packages use a portable electric heater to get rid of any moisture buildup. Leave coverings loose to permit air circulation and to allow for periodic inspection.

The unit should be stored at least 3½ inches (89 mm) off the floor on wooden blocks covered with moisture proof paper or polyethylene sheathing. Aisles between parts and along all walls should be provided to permit air circulation and space for inspection.

Outdoor - Fans designed for outdoor applications may be stored outdoors, if absolutely necessary. Roads or aisles for portable cranes and hauling equipment are needed.

The fan should be placed on a level surface to prevent water from leaking into the fan. The fan should be elevated on an adequate number of wooden blocks so that it is above water and snow levels and has enough blocking to prevent it from settling into soft ground. Locate parts far enough apart to permit air circulation, sunlight and space for periodic inspection. To minimize water accumulation, place all fan parts on blocking supports so that rain water will run off.

Do not cover parts with plastic film or tarps as these cause condensation of moisture from the air passing through heating and cooling cycles.

Fan wheels should be blocked to prevent spinning



caused by strong winds.

Inspection and Maintenance During Storage

While in storage, inspect fans once per month. Keep a record of inspection and maintenance performed.

If moisture or dirt accumulations are found on parts, the source should be located and eliminated. At each inspection, rotate the wheel by hand ten to fifteen revolutions to distribute lubricant in motor and bearings. If paint deterioration begins, consideration should be given to touch-up or repainting. Fans with special coatings may require special techniques for touch-up or repair.

Machined parts coated with rust preventive should be restored to good condition promptly if signs of rust occur. Immediately remove the original rust preventive coating with petroleum solvent and clean with lint-free cloths. Polish any remaining rust from surface with crocus cloth or fine emery paper and oil. Do not destroy the continuity of the surfaces. Thoroughly wipe clean with Tectyl® 506 (Ashland Inc.) or the equivalent. For hard to reach internal surfaces or for occasional use, consider using Tectyl® 511M Rust Preventive, WD-40® or the equivalent.

Removing from Storage

As fans are removed from storage to be installed in their final location, they should be protected and maintained in a similar fashion until the fan equipment goes into operation.

Dimensional Data

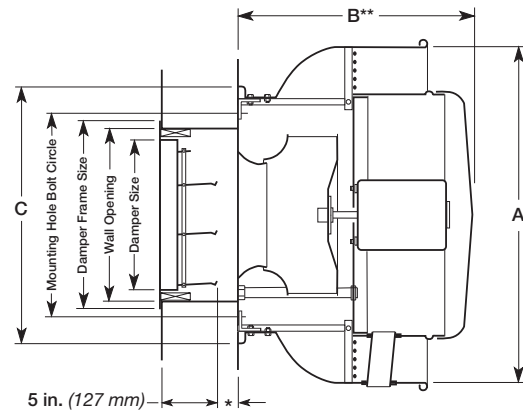

XSED - Direct Drive Dimensions

Model	A	B**	C	Wall Opening	Damper Size	Damper Frame Size	Mounting Bolt Circle
XSED-060, 065, 070, 075	18 ³ / ₈ (467)	13 ¹ / ₂ (343)	14 ³ / ₄ (375)	8 ¹ / ₂ (216)	8 (203)	10 (254)	11 ³ / ₄ (298)
XSED-080, 085, 090	21 (533)	13 ³ / ₈ (340)	17 ⁷ / ₈ (454)	10 ¹ / ₂ (267)	10 (254)	12 (305)	15 (381)
XSED-095	21 (533)	15 ¹ / ₄ (387)	17 ⁷ / ₈ (454)	10 ¹ / ₂ (267)	10 (254)	12 (305)	15 (381)
XSED-098, 101, 121, 131	24 ⁷ / ₈ (632)	28 ¹ / ₄ (718)	19 ³ / ₄ (502)	12 ¹ / ₂ (318)	12 (305)	14 (356)	16 ⁷ / ₈ (429)
XSED-141, 161	28 ⁷ / ₈ (733)	29 ³ / ₄ (756)	22 ¹ / ₈ (562)	15 ¹ / ₂ (394)	15 (381)	17 (432)	19 ³ / ₈ (492)
XSED-180, 200	35 ³ / ₈ (905)	28 ⁵ / ₈ (727)	27 ³ / ₄ (705)	17 ¹ / ₂ (445)	17 (432)	19 (483)	25 (635)

All dimensions in inches (millimeters). *NOTE: 2 inches minimum, 8 inches when motorized option is required. **May vary depending on motor size.

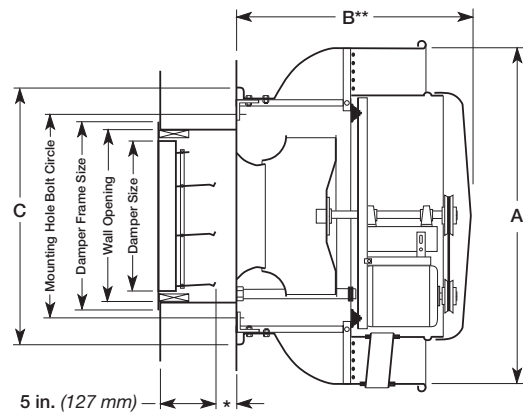

XSEB - Belt Drive Dimensions

Model	A	B**	C	Wall Opening	Damper Size	Damper Frame Size	Mounting Bolt Circle
XSEB-098, 101, 121, 131	24 ⁷ / ₈ (632)	28 ¹ / ₄ (718)	19 ³ / ₄ (502)	12 ¹ / ₂ (318)	12 (305)	14 (356)	16 ⁷ / ₈ (429)
XSEB-141, 161	28 ⁷ / ₈ (733)	29 ³ / ₄ (756)	22 ¹ / ₈ (562)	15 ¹ / ₂ (394)	15 (381)	17 (432)	19 ³ / ₈ (492)
XSEB-180, 200	35 ³ / ₈ (899)	28 ⁵ / ₈ (727)	27 ³ / ₄ (705)	17 ¹ / ₂ (445)	17 (432)	19 (483)	25 (635)
XSEB-220, 240	42 ²⁵ / ₃₂ (1087)	33 ⁷ / ₈ (860)	31 ¹ / ₄ (794)	20 ¹ / ₂ (521)	20 (508)	22 (559)	28 ³ / ₈ (721)
XSEB-300	50 (1270)	36 (914)	38 ³ / ₈ (975)	25 ¹ / ₂ (648)	25 (635)	27 (686)	35 ²⁷ / ₃₂ (910)

All dimensions in inches (millimeters). *NOTE: 2 inches minimum, 8 inches when motorized option is required. **May vary depending on motor size.



Installation

These fans exhaust directly away from the building, therefore their location and placement should be analyzed. Proximity to nearby buildings and people must be considered.

Access to the motor compartment is accomplished by removing the screws from the cover. The cover can then be removed and placed on a flat surface in an area protected from strong winds.

The motor's amperage and voltage rating must be checked for compatibility to the supply voltage prior to final electrical connection. For commercial kitchen applications, the electrical supply must enter the motor compartment through the breather tube. For other non-flammable applications the electrical supply can be routed through the conduit chase between the mounting plate and the bottom of the motor compartment. Consult local code authorities for your specific requirements.

Typical Wall Mounting Installation

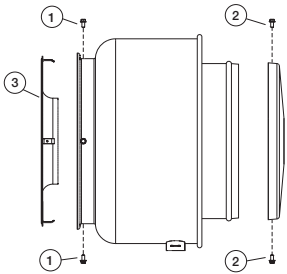

Figure 1

1. Remove mounting plate from unit by removing the fasteners marked by (1). Remove motor compartment cover by removing fasteners marked by (2). *Reference Figure 1.*

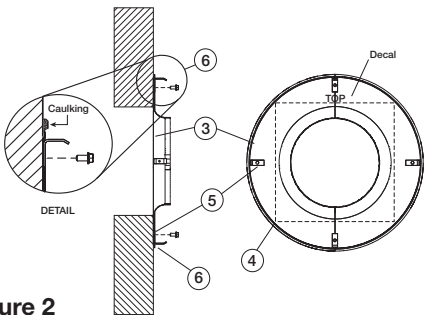

Figure 2

2. Locate the mounting plate (3) at the desired position and check to avoid unit clearance problems. Cut the wall opening (4) as shown based upon dimensions obtained from the Dimensional Data section found on page 2. Locate top of mounting plate (decal) and attach to the wall construction. The fasteners must pass through the holes provided in the mounting angle clips (5) on the mounting plate (3). For uneven surfaces, shims may be required. Sealant or caulk should be applied in the groove (6) formed by the mounting plate and the wall to prevent moisture leakage into the building. *Reference Figure 2.*

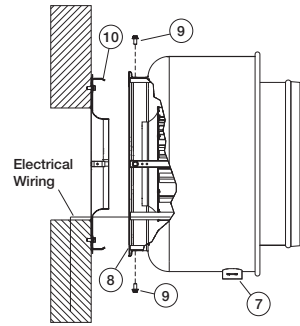

Figure 3

3. Once the mounting plate has been attached to the wall, the unit can be installed. The unit should be aligned with the breather tube (7) pointing down. The electrical chase should be guided through the hole in the motor compartment. The horizontal support channels (8) should slide over the mounting angle clips (10) on the mounting plate until the holes in the windband and clips are aligned. Replace fasteners (9) and tighten. Wiring now can be done. Consult local code authorities for your specific requirements. *Reference Figure 3.*

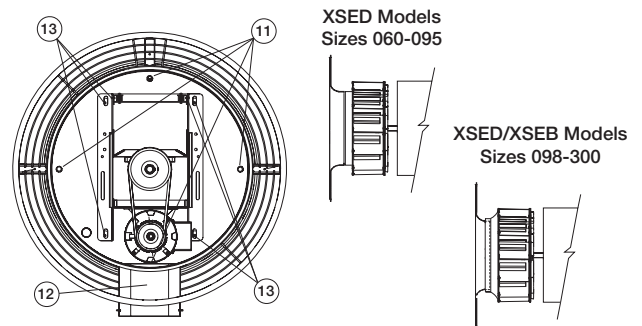

Figure 4

4. During shipping, wheel position may shift. Alignment should be as shown above (centered in the inlet) and can be accomplished by loosening the fasteners (11) located in the motor compartment. For belt drive units, additional vertical alignment can be accomplished by loosening the four fasteners on the drive frame support angles and the two fasteners that hold the L-brackets to the support angles on top (13). Also, horizontal alignment can be made by loosening the bearings from the bearing plate.

Removal of the entire power pack (motor, drives and wheel) for maintenance or cleaning can be accomplished by removing the breather tube (12) and fasteners (11). *Reference Figure 4.*



Commercial Kitchen Installation

UL/cUL 762 Listed fans are for commercial kitchen installations. XSED fans with A, B and C motor RPMs and all XSEB fans are the only fans approved for this type of installation. All must include the model suffix "G".

For commercial kitchen installations, the electrical supply must enter the motor compartment through the breather tube of the fan. In addition, the maximum operating temperature at the fan must not exceed 400°F (204°C).

Commercial kitchen installations must also comply with NFPA 96. Check local and national codes for these installations, and consult local code authorities for other specific requirements.

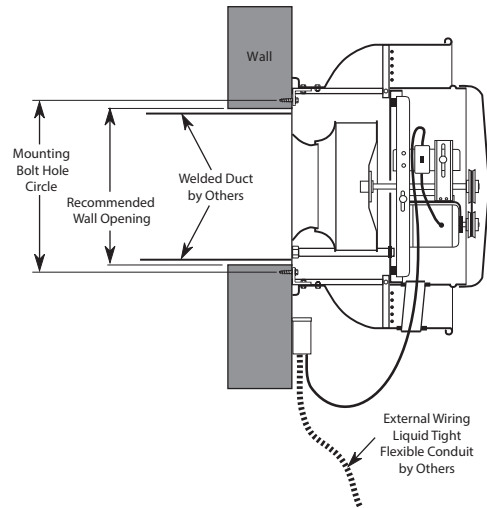

Mounting for Severe Duty Installations

IMPORTANT

Only qualified installers should perform this work. Manufacturer assumes no liability for damages resulting from installation.

Installation instructions for seismic ratings are only recommendations. Final design must be determined by Structural Engineer of Record (SEOR) including requirements for installation of mounting plate to structure.

For severe duty installations, secure the mounting plate to the wall using the correct number and type of fasteners shown in the table and drawings.

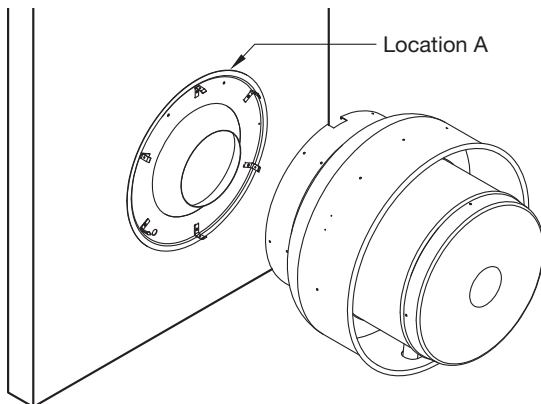

High Wind and Seismic Mounting - Location A

Fan Size	Total Fasteners
060 - 161	16
180 - 300	24

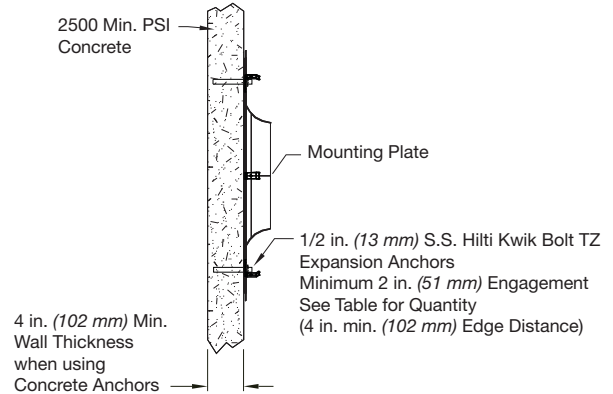

Concrete Anchoring

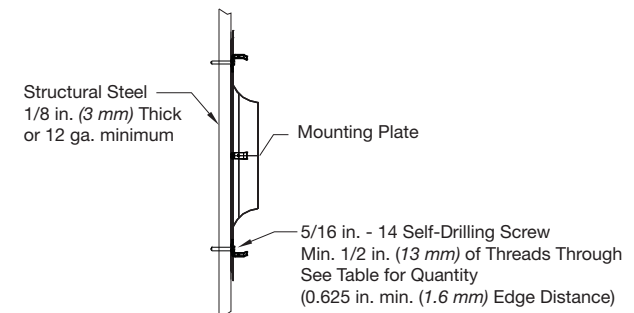

Steel Anchoring

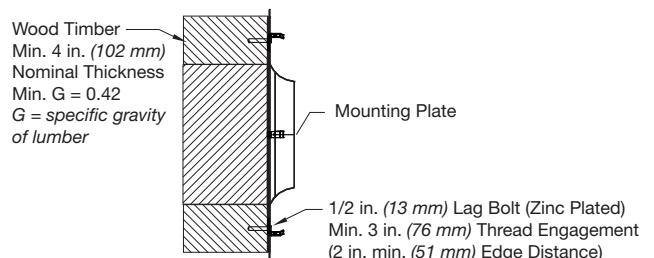

Timber Anchoring



Pre-Starting Checks

DANGER

Disconnect and secure to the “off” position all electrical power to the fan prior to inspection or servicing. Failure to comply with this safety precaution could result in serious injury or death.

DANGER

Pour écarter les risques de blessure grave ou de mort, débrancher et verrouiller l’alimentation électrique en position « Arrêt » avant tout contrôle ou entretien.

1. Check all fasteners and setscrews for tightness. The wheel should rotate freely and be aligned as shown in Figure 5.

Fan Size	Overlap in. (mm)	Gap in. (mm)
060-095	–	3/32 (2)
098-161	1/4 (6)	–
180-300	1/2 (13)	–

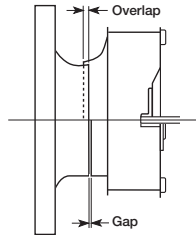

Figure 5

2. Wheel position is preset and the unit is test run at the factory. Movement may occur during shipment and realignment may be necessary. Refer to steps 3 and 4.
- 3 **Only XSEB model** - Centering can be accomplished by loosening the bolts holding the drive frame to the shock mounts and repositioning the drive frame.
4. Wheel and inlet cone overlap can be adjusted by loosening the setscrews in the wheel and moving the wheel to the desired position. For both XSED and XSEB models with wheel hubs and shaft pulleys utilizing a tapered bushing interface, reference page 9 for the tapered bushing removal and move the wheel to the desired position. Fan RPM should be checked and verified with a tachometer.
5. Check wheel rotation (viewing from the shaft side) by momentarily energizing the unit. Rotation should be clockwise and correspond to the rotation decal on the unit, see Figure 6.

If wheel rotation is incorrect, reverse two of the wiring leads or check motor wiring for single phase.

All XSED and XSEB models have clockwise rotation when viewed from top of fan.

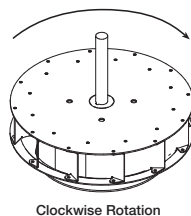

Figure 6

WARNING

Correct direction of wheel rotation is critical. Reversed rotation will result in poor air performance, motor overloading and possible motor burnout.

AVERTISSEMENT

La turbine doit impérativement tourner dans le bon sens. Une rotation en sens inverse entraînerait de mauvaises performances de soufflage, une surcharge du moteur voire un grillage du moteur.

Model XSEB Pre-Starting Belt Tension Checks

6. Always loosen tension enough to install belts without stretching, see Figure 7.
Do not force belt(s). Forcing the belts will break the cords and cause belt failure.

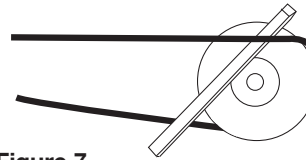

Figure 7

7. For units with two groove pulleys, adjust so the tension is equal in both belts.
8. If adjustments are made, it is very important to check the pulleys for proper alignment. Misaligned pulleys lead to excessive belt wear, vibration, noise and power loss, see Figure 8.

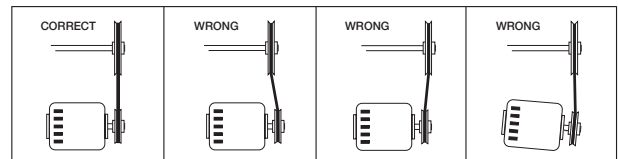

Figure 8

9. Belt tension can be adjusted by loosening four fasteners on the drive frame, see Figure 9. The motor plate slides on the slotted adjusting arms and drive frame angles in the same manner.

Four (4) fasteners in total.

Identical fasteners on opposing side must also be loosened.

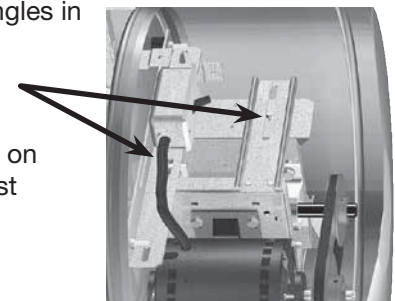

Figure 9



10. **Sizes 099-161:** Belts should be tensioned just enough to prevent slippage at full load. Belts should have a slight bow on the slack side while running at full load; see Figure 10a.

Sizes 180-300: Belt tension should be adjusted to allow 1/64 in. (0.397 mm) of deflection per inch of belt span. For example, a 15 in. (381 mm) belt span should have 15/64 in. (0.234 mm) (or about 1/4 in. (6 mm)) of deflection with moderate thumb pressure at mid-point between pulleys; see Figure 10b.

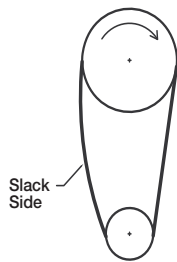

Figure 10a

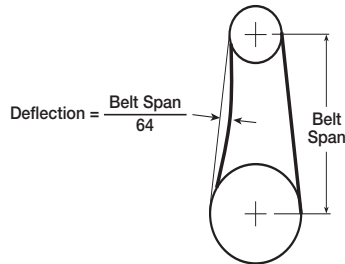

Figure 10b

11. The adjustable motor pulley is factory set for the RPM specified. Speed can be increased by closing or decreased by opening the adjustable motor pulley. Two groove variable pitch pulleys must be adjusted an equal number of turns open.
12. Any increase in speed represents a substantial increase in the horsepower required by the unit.
13. Motor amperage should always be checked to avoid serious damage to the motor when speed is varied.

IMPORTANT

Over tightening belts will cause excessive bearing wear and noise. Too little tension will cause slippage at startup and uneven wear.

IMPORTANT

The fan has been checked for mechanical noises at the factory prior to shipment. If mechanical noise should develop, suggested corrective actions are offered in the Troubleshooting section.

Operation

1. Before starting up or operating fan, check all fasteners for tightness. In particular, check the set screws in the wheel hub (or the tapered bushing and pulleys if applicable).
2. While in the OFF position or before connecting the fan to power, turn the fan wheel by hand to be sure it is not striking the venturi or any obstacle.
3. Start the fan and shut it off immediately to check rotation of the wheel with directional arrow in the motor compartment, see Figure 6.
4. When the fan is started, observe the operation and check for any unusual noises.
5. With the system in full operation and all ductwork attached, measure current input to the motor and compare with the nameplate rating to determine if the motor is operating under safe load conditions.
6. Keep inlets and approaches to fan clean and free from obstruction.

Inspection

Inspection of the fan should be conducted at the first 30 minute and 24 hour intervals of satisfactory operation.

30 Minute Interval

Inspect bolts, setscrews and motor mounting bolts. Adjust and tighten as necessary.

24 Hour Interval

Check all internal components. On XSEB unit only, inspect belt alignment and tension. Adjust and tighten as necessary.

IMPORTANT

Adjust (tighten) belt tension after the first 24-48 hours of operation.

Maintenance

DANGER
Disconnect and secure to the “off” position all electrical power to the fan prior to inspection or servicing. Failure to comply with this safety precaution could result in serious injury or death.
DANGER
Pour écarter les risques de blessure grave ou de mort, débrancher et verrouiller l’alimentation électrique en position « Arrêt » avant tout contrôle ou entretien.
IMPORTANT
Uneven cleaning of the wheel will produce an out of balance condition that will cause vibration in the fan.
WARNING
This unit should be made non-functional when cleaning the wheel or housing (fuses removed, disconnect locked off).
AVERTISSEMENT
L’appareil doit être rendu non opérationnel lors du nettoyage de la turbine ou du caisson (fusibles retirés, sectionneur verrouillé).

Installation and maintenance are to be performed only by qualified personnel who are familiar with local codes and regulations and who are experienced with this type of equipment.

Motor maintenance is generally limited to cleaning and lubrication (where applicable). Cleaning should be limited to exterior surfaces only. Removing dust buildup on motor housing ensures proper motor cooling.

Greasing of motors is only intended when fittings are provided. Many fractional horsepower motors are permanently lubricated and should not be lubricated after installation. Motors supplied with grease fittings should be greased in accordance with manufacturers’ recommendations. Where motor temperatures do not exceed 104°F (40°C), the grease should be replaced after 2,000 hours of running time as a general rule.

Wheels require very little attention when moving clean air. Occasionally, oil and dust may accumulate causing imbalance. When this occurs, the wheel and housing should be cleaned to ensure smooth and safe operation.

All fasteners should be checked for tightness each time maintenance checks are performed prior to restarting unit.

A proper maintenance program will help these units deliver years of dependable service.

Maintenance for XSEB Model

1. Belts tend to stretch after a period of time. They should be checked periodically for wear and tightness. When replacing belts, use the same type as supplied with the unit.
2. Matched belts should always be used on units with multi-groove pulleys.
3. For belt replacement, loosen the tensioning device enough to allow removal of the belt by hand. Do not force the belts on or off. This may cause cords to break, leading to premature failure.
4. Once installed, adjust belts as shown in “Pre-Starting Checks”.
5. To ensure tightness, check pulley setscrews. Proper keys must be in keyways.
6. Fan RPM should not be readjusted. Only use pulleys of identical size and type when replacing pulleys.
7. Shaft bearings can be classified in two groups, relubricating and non-relubricating. All non-relubricating bearings on model XSEB fans are factory lubricated and require no further lubrication under normal use; between -20° to 180°F (-29° to 82°C) in a relatively clean environment.
8. On XSEB belt driven fans, the cast pillow block bearings are factory lubricated and are provided with external grease fittings. Annual lubrication is recommended or more frequently if needed (see Table 2 on page 9). Do not over-grease. Use only one or two shots of lubricant with a hand gun. Maximum hand gun rating is 40 psi. Rotate bearings during lubrication where good safety practice permits. Caution should be employed to prevent over packing or contamination.
9. Units installed in hot, humid or dirty locations should be equipped with special bearings. These bearings will require frequent lubrication. Caution should be employed to prevent over packing or contamination.
10. Grease fittings should be wiped clean. The unit should be in operation while lubricating bearings. Extreme care should be used around moving parts.
11. Grease should be pumped in very slowly until a slight bead forms around the seal. A high grade lithium base grease should be used.
12. During the first few months of operation, check bearing set screws periodically to ensure tightness.
13. When installing fans for restaurant exhaust applications, follow NFPA 96 for cleaning fans.
14. If unit is to be left idle for an extended period, remove belts and store in a cool, dry place to avoid premature belt failure.



Tapered Bushing Hub Installation and Removal

For wheel hubs and shaft pulleys utilizing a tapered bushing interface, follow this procedure for installation and removal. There are two possible set ups for the tapered bushing, both have the same procedure, but orientation of the hub varies.

Tapered Bushing Removal:

1. If present, loosen the setscrew holding the bushing and shaft key in place.
2. Loosen and remove the socket head cap screws which fasten the bushing to the hub as shown in the section views and examples of Figures 11-14.

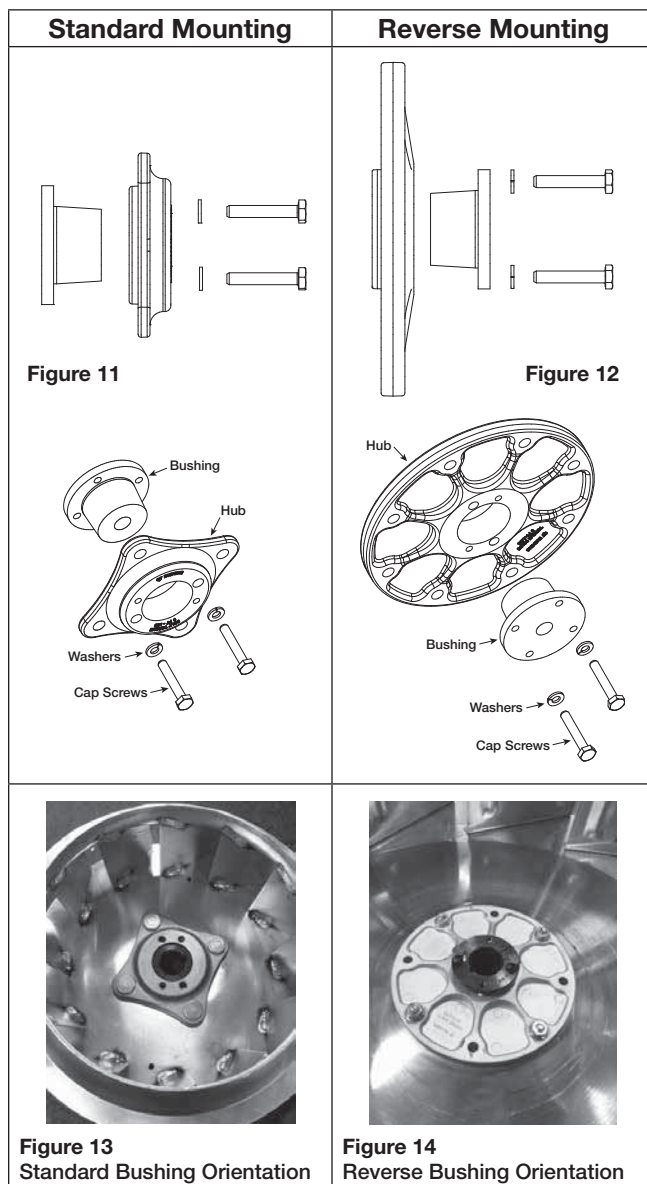

3. **Standard Mounting** - Take the two socket head cap screws that were removed and install them into the visibly threaded holes on the wheel hub.
Reverse Mounting - Install the two socket head cap screws into the visibly threaded holes of the bushing flange.

4. Once both socket head cap screws are installed, tighten them an eighth of a turn at a time, alternating between the two until the hub comes loose from the bushing.

Bushing Installation:

1. Clean all surfaces of hub and bushing to remove any oil or residue present and do not use any lubricant to install bushing into the hub. For both standard and reverse mounting styles, the socket head cap screws are adjustable from the inlet of the fan.
2. **Standard Mounting:** Slide the bushing and shaft key onto the fan shaft followed by the wheel and hub assembly. If present, use the keyway setscrew to hold the shaft key and bushing in place but **DO NOT** overtighten as this can damage the bushing. Align the unthreaded holes of the hub with the threaded holes of the tapered bushing.
Reverse Mounting: Slide the wheel and hub assembly onto the fans shaft followed by the bushing and shaft key. If present, use the keyway setscrew to hold the shaft key and bushing in place but **DO NOT** overtighten as this can damage the bushing. Align the unthreaded holes of the tapered bushing with the threaded holes of the hub.
3. Install the two bushing socket head cap screws into the aligned holes by hand (or without excessive torque) until the heads of the socket head cap screws are seated against the mating surface.
4. Adjust the height of the wheel in the fan relative to the inlet venturi then tighten the two socket head cap screws an eighth turn at a time in an alternating fashion and to a torque of 10 ft-lbs.

Recommended Bearing Lubrication Frequency in Months

If unusual environment conditions exist, such as extreme temperature, moisture or contaminants, more frequent lubrication is required.

A good quality lithium base grease, conforming to NLGI Grade 2 consistency, such as those listed in Table 3.

Table 2: Suggested Fan Bearing Lubrication Intervals

Interval (months)	Type of Service
1 to 3	Heavy duty in dirty, dusty locations; high ambient temperatures; moisture laden atmosphere; vibration.
3 to 6	12 to 24 hours per day, heavy duty, or if moisture is present
6 to 12	8 to 16 hours per day in clean, relatively dry atmosphere
12 to 18	Infrequent operation or light duty in clean atmosphere

Table 3: Grease Manufacturers

Manufacturer	Grease (NLGI #2)
U.S. Electric Motors	Grease No. 83343
Chevron U.S.A. Inc	Chevron SRI Grease #2
Mobil Oil Corporation	Mobilith
	Mobil 532
Texaco, Inc.	Premium BRB #2
	Texaco Multifak #2
Amoco Oil Co.	Rykon Premium #2
Exxon	Unirex N2
Shell	B Shell Alvania #2

Parts List

CAUTION

A fan manufactured with an explosion resistant motor does not certify the entire unit to be explosion proof. Refer to UL Listing Mark for the fans approved usage.

CAUTION

La présence d'un moteur antidéflagrant sur un ventilateur ne garantit pas que tout l'appareil est antidéflagrant. Pour connaître les emplois autorisés de l'appareil, voir son marquage de conformité UL.

Each fan bears a manufacturer's nameplate with model number and serial number embossed. This information will assist the local Accurex representative and the factory in providing service and replacement parts. Before taking any corrective action, make certain unit is not capable of operation during repairs.

XSED Direct Drive

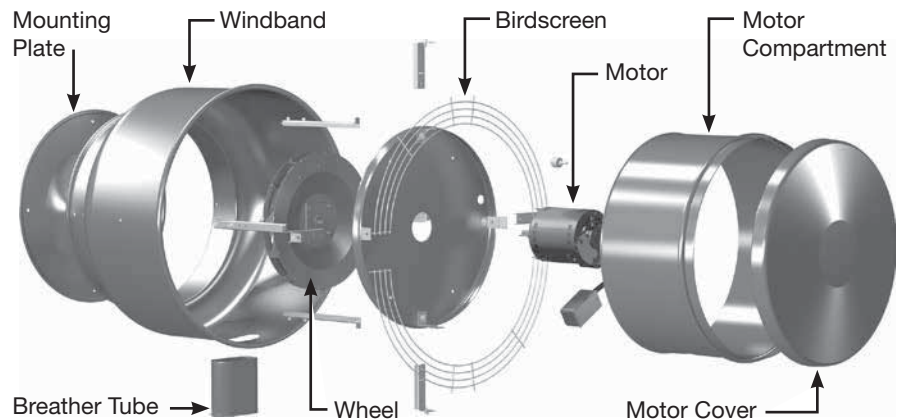

XSEB Belt Drive

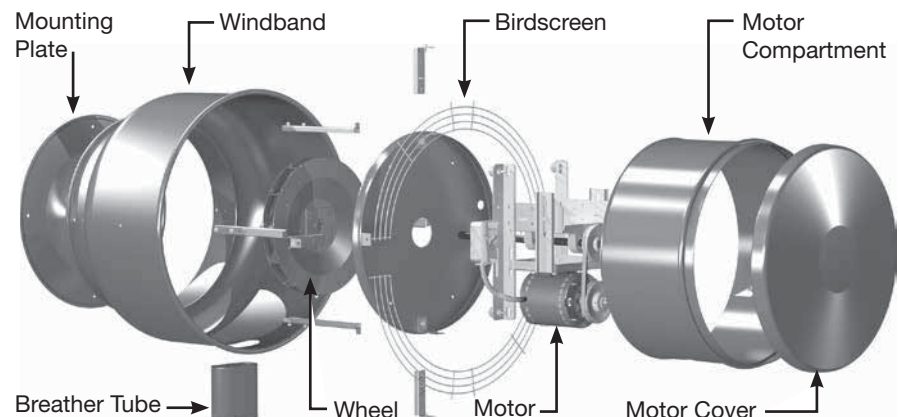

Troubleshooting

WARNING

Before taking any corrective action, make certain unit is not capable of operation during repairs.

AVERTISSEMENT

Avant d'entreprendre toute action corrective, s'assurer que l'appareil ne pourra pas fonctionner durant les réparations.

PROBLEM	CAUSE	CORRECTIVE ACTION
Excessive noise or vibration	Bad bearings	Replace.
	Wheel unbalance	Clean and remove all dirt buildup off wheel. Check wheel balance, rebalance in place if necessary.
	Belts too tight or too loose	Adjust tension, see Figures 10a and 10b.
	Wheel improperly aligned and rubbing	Center wheel on inlet, see Figure 5.
	Loose drive or motor pulleys	Align and tighten. See Pre-Starting Checks on pages 6 and 7.
	Foreign objects in wheel or housing	Remove objects, check for damage or unbalance.
Reduced airflow	System resistance too high	Check system: Proper operation of backdraft or control dampers, obstruction in ductwork, clean dirty filters.
	Unit running backwards	Correct as shown in Pre-Starting Checks, #5, Figure 6.
	Excessive dirt buildup on wheels	Clean wheel.
	Improper wheel alignment	Center wheel on inlets, see Pre-Starting Checks, Figure 5.



Our Commitment

As a result of our commitment to continuous improvement, Accurex reserves the right to change specifications without notice.

Specific Accurex product warranties are located on accurex.com within the product area tabs and in the Library under Warranties.



P.O. Box 410 Schofield, WI 54476
Phone: 800.333.1400 • Fax: 715.241.6191
Parts: 800.355.5354 • www.accurex.com